

HV500

Single Pole - Normally Open - High Voltage Contactor

Higher D.C. voltage requirements are an increasing necessity in today's world. In a field that requires innovation and cost efficiency, Albright has extended our comprehensive Contactor range to include voltages up to 1000 volts and full hermetic sealing.

The Albright High Voltage series are directly compatible with existing contactors within the market. Albright have over 70 years' experience of designing contactors for the most demanding applications.



Specification:

- Single Pole - Normally Open
- Rated Contact Voltage 12V - 1000V D.C.
- Current Thermal Rating up to 500 Amps
- Hermetically Sealed
- Non-Polarity Sensitive
- PWM Coil Economiser Option
- Coil Reverse Polarity Protection

- Auxiliary Switch:
Normally Open,
Normally Closed
Mirror
- Magnetic Latching Option
- Silver Contacts Option
- UL Recognised

*Please check our website for
product UL Recognition status*

Applications include:

- Automotive - Vehicle & Charging
- Battery Management Systems
- Power Distribution Units
- Renewable Energy

HV500



Single Pole
Normally Open
Full Hermetic Sealing
12V - 1000V D.C.
500A

Specification	
Rated Contact Voltage	12V - 1000V D.C.
Continuous Operating Current	250A (50mm ² or 1-1/0 AWG cables)
Continuous Operating Current (Max)	500A (190mm ² or 350 MCM busbars)
Coil Voltage Range	12V D.C. - 96V D.C.
Contact Arrangement:	
Main	SPST-NO
Auxiliary:	SPST-NO
	SPST-NC
	SPST-NC Mirror
Mechanical Durability:	
Main	>10 ⁶ Cycles
Auxiliary	>10 ⁵ Cycles
Make/Break Current at Various Voltages (See page 4)	
Voltage Drop	<30mV at 100A
Insulation Resistance	>200MΩ
Dielectric Withstand Test (at Sea Level):	4000V D.C./Leakage <1mA
Maximum Altitude	3000m
Environmental Seal	Contacts, Auxiliary and PWM Circuit Hermetically Sealed - Exceeds IP67

Characteristics	
Weight:	
Switch	400 gms
Bracket	20 gms
Connection Wire Length:	
Coil	250mm
Auxiliary	280mm
Shock, 1/2 Sine, 11ms (G):	
Closed	20G Peak
Open	20G Peak
Vibration, Sinusoidal	80 - 2000Hz Peak 20G
Temperature - Operating	- 45°C to + 85°C*
Temperature - Storage	- 45°C to + 120°C
Humidity	5 - 85%

* Higher temperatures are possible with Current derating of contactor or suitable connecting terminals.

HV500 Features:

- Fully Hermetically Sealed
- Non-Polarity Sensitive
- PWM Coil Economiser Option
- Coil Reverse Polarity Protection*
- Coil Suppression*
- Auxiliary Switch - Normally Open or Normally Closed Options
- Auxiliary Switch - Mirror (Normally Closed) Option
- Magnetic Latching Option
- Silver Contacts Option

* When factory fitted with PWM board

Auxiliary Switch Data	
Switching capabilities (Resistive Load)	1A at 24V D.C.
Minimum Current	100mA at 12V
<i>Note: Rating increase review underway</i>	

Terminals

Coil	Stripped Wires (Cables are 0.325mm ² or 22 AWG)
Auxiliary	Stripped Wires (Cables are 0.325mm ² or 22 AWG)
Main Contacts	Male (M8, M10) or Female (M6, M8)

HV500 Part Numbering

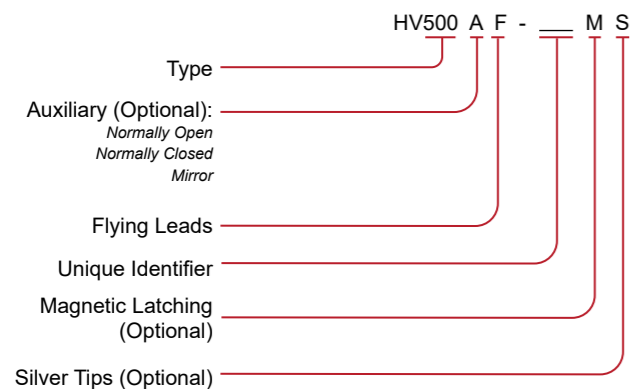

HV500 Outline Dimensions

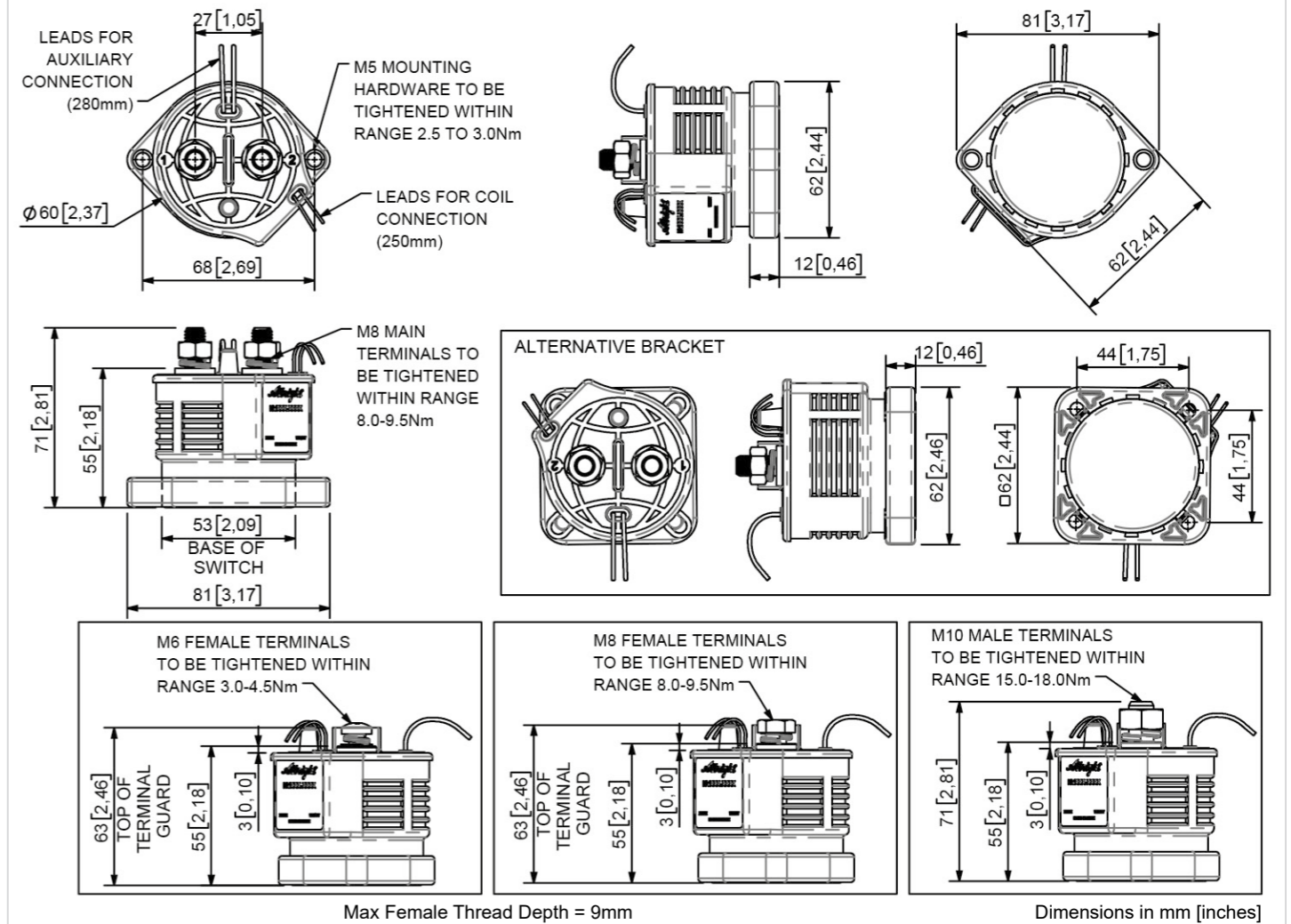

HV500 Terminal Guard

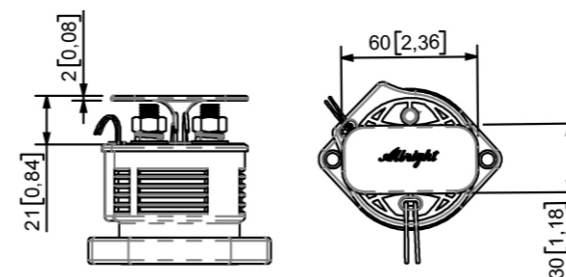

HV500



Note: Albright recommend that the screw fixture is accompanied by a flat and spring washer assembly

HV500

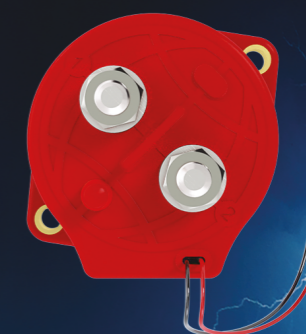

Single Pole
Normally Open
Full Hermetic Sealing
12V - 1000V D.C.
500A

D.C. Power Switching Cycles

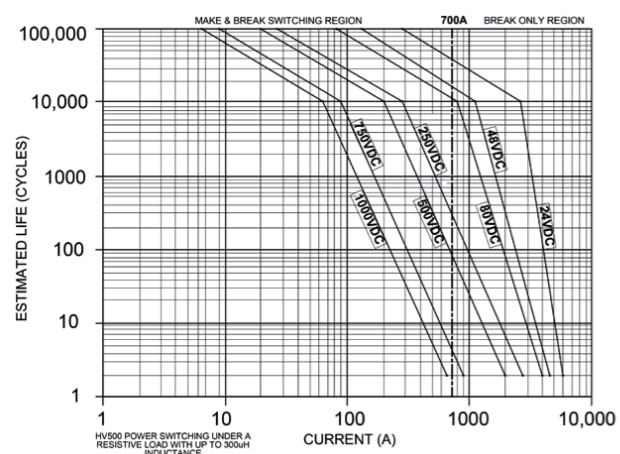

Notes:

1. For resistive loads with 300µH maximum inductance.
2. Estimates based on extrapolated data.
3. End of life is reached when insulation resistance is < 50MΩ @ 500V.
4. For currents > 700A only break is permitted to avoid tack welding, duty cycle 1%, 600 seconds duration.
5. For currents < 700A make & break is permitted duty cycle 10%, 6 seconds duration.
6. Users are advised to verify actual performance in end application.
7. Main Contacts are not polarity sensitive.

D.C. Power Switching Cycles

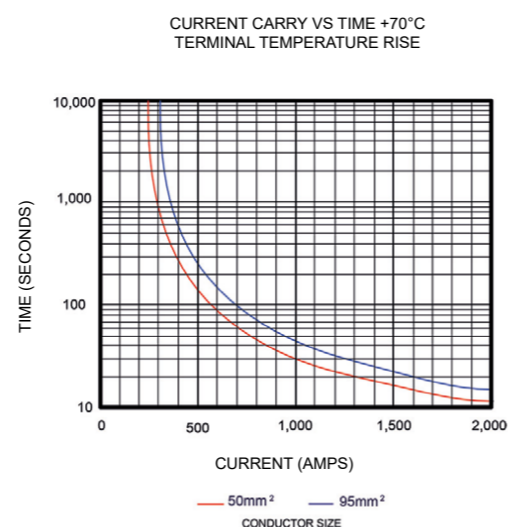

Note:

Chart data is with clean contacts that have not switched load.

Connection Diagrams

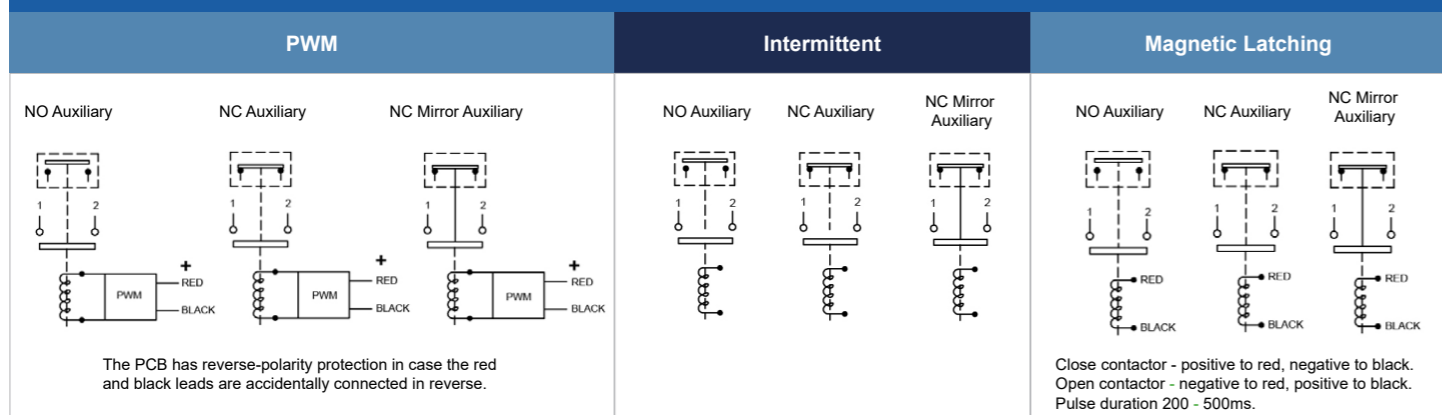

Notes

- Main Contacts are not polarity sensitive
- Intermittent (INT) coils must be operated with Customers own PWM circuit
- For other short duty application requirements (such as pump control circuits), please contact Albright Technical

Coils

Circuit	PWM/INT	PWM/INT	PWM/INT	PWM/INT	PWM/INT	PWM/INT	PWM/INT	PWM/INT
Voltage (V)	12	24	36	48	60	72	84	96
Pull-In Voltage (V)	9	18	27	36	45	54	63	72
Pull-In Power (W)	27	27	27	27	27	27	27	27
Drop Out (V) ²	4.8	9.6	14.4	19.2	24.0	28.8	33.6	38.4
Voltage Maximum (V)	18	36	54	72	90	108	120	120
Coil Power (W) ¹	3	3	3	3	3	3	3	3
Back EMF (V) ²	0	0	0	0	0	0	0	0
Pull-In Time (ms)	< 20	< 20	< 20	< 20	< 20	< 20	< 20	< 20
Drop-Out Time (ms)	< 5	< 5	< 5	< 5	< 5	< 5	< 5	< 5

¹ Available ranges shown. Holding coil power is determined by Application requirements - high power contactors are recommended for interrupted switching applications. Please contact Albright Technical for further advice.

² When factory fitted with PWM board. Please contact Albright Technical for further advice for Intermittent (INT) coil.

Circuit	Magnetic Latching	Magnetic Latching	Magnetic Latching	Magnetic Latching	Magnetic Latching	Magnetic Latching	Magnetic Latching	Magnetic Latching
Voltage (V)	12	24	36	48	60	72	84	96
Close/Open Voltage (V)	6	12	18	24	30	36	42	48
Close/Open Power (W)	12	12	12	12	12	12	12	12
Back EMF (V)	Application Dependant - contact Albright Technical for advice							
Pull-In Time (ms)	< 20	< 20	< 20	< 20	< 20	< 20	< 20	< 20
Drop-Out Time (ms)	< 20	< 20	< 20	< 20	< 20	< 20	< 20	< 20

Notes

- Intermittent (INT) coils must be used in conjunction with Customers own PWM circuit. For other short duty application requirements (such as pump control circuits), please contact Albright Technical.
- Magnetic Latch - Contact position is secured with the use of a permanent magnet within the coil assembly. The coil requires a pulse (~500ms) to close the contacts, and a reverse polarity pulse (200 - 500ms) to operate the armature and open the contacts, but otherwise remains in the last energised state without the need for power. It should therefore be noted these are not failsafe.
- Where applicable values shown are at 20°C.
- PWM is not compatible with ramped supply voltages.
- PWM operation is reliant on smooth DC supply.
- For customers supplying their own PWM, a minimum frequency of 10kHz is recommended, but optimum performance is obtained in the range of 15 - 20 kHz
- Further coil specifications available. Please contact Albright Technical for further advice.

HV500



Single Pole
Normally Open
Full Hermetic Sealing
12V - 1000V D.C.
500A

Auxiliary



An optional microswitch is available in Normally Open (White connection wires), Normally Closed (Blue connection wires), or Mirror (Orange connection wires) contact form.

The Mirror Auxiliary Contact option allows for a failsafe signal for the status of the main contacts in normal running and when in a situation where there is a fault. The mirror contact function conforms to EN 60947-4-1, Annex F, with the requirement for a suitable design of Auxiliary Contact to be linked with main power contacts. Furthermore, it conforms to EN 60947-5-1, Annex L as a highly reliable method of monitoring the status of the contactor, in conjunction with further aspects of the customers' design.

Coil

The versatility of the HV500 allows a variety of coil options that include:

- **Intermittent Duty** - for switching on load or for customers own PWM solution.
- **PWM Coil Economiser** - allowing for significantly reduced power consumption while maintaining optimum switching capability.
- **Magnetic Latching** - for zero power consumption in stationary applications.

Connection Polarity

Main Contacts are not polarity sensitive.

Coil Connections for PWM and Magnetic Latching options should follow connection diagram advice on page 4.

Hermetic Sealing

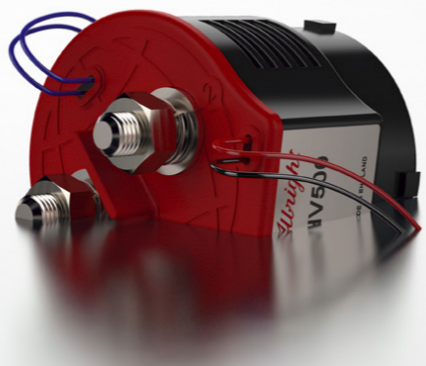

The Albright HV range is fully hermetically sealed, allowing for durability in extreme environments, or where operating in potentially hazardous conditions. Please note, hermetic sealing also includes the PWM circuit, where fitted.

Silver Alloy Tips



Silver alloy tips can be specified when frequent load switching is required. Albright has a specialised history in heavy current switching, and our HV500 has been designed from conception to be capable of switching heavy loads.

Bracket

Mounting is through a rotatable bracket which offers 6 angles for orientation. This allows for complete flexibility with the position of main contacts, allowing for customer ease of connection. Recommended panel mounting tightening torque is 2.5Nm to 3Nm.



Fixings

Main Terminals	Torque
M6 Female	3.0 - 4.5Nm
M8 Male (Standard)	8.0 - 9.5Nm
M8 Female	8.0 - 9.5Nm
M10 Male	15.0 - 18.0Nm
Mounting	
Bracket	2.5 - 3.0Nm

Notes

- An optional Terminal Guard is available, protecting the main terminals from accidental contact.
- The main contacts are not polarity sensitive. Terminals can be marked 1 and 2 as required.
- Our dedicated Technical Staff will assist with any application or specification requirements. Please contact them at your local office or via email: technical@albrightinternational.com
- PWM is not compatible with ramped supply voltages.
- PWM operation is reliant on smooth DC supply.
- Performance data provided should be used as a guide only. De-rating or variation from figures may be necessary according to application.
- Thermal current ratings stated are dependant upon the size of conductor being used.
- If the application has capacitors, pre-charging will be required.
- Albright reserve the right to change data without prior notice.
- HV Contactors because of Hermetic Sealing are not serviceable.
- Options including brackets and Terminal guards can be supplied fitted or provided separately.

Contactors are our speciality, and we recommend that customers seek technical advice for their applications.

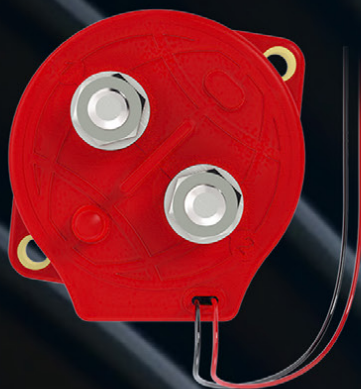

Please Note:

- Performance data provided should be used as a guide only. Some de-rating or variation from figures may be necessary according to application.
- Thermal current ratings stated are dependent upon the size of conductor being used
- For further technical advice email: technical@albrightinternational.com
- Albright reserve the right to change data without prior notice
- Design Patent Approved
- US Patent No 11,004,636
- UL Recognised

Please check our website for product UL Recognition status

www.albrightinternational.com

