

F11



Content	Page
Specifications	9
Efficiency	10
Noise level	10
Selfpriming speed and required inlet pressure	11
Ordering codes	
F11-CETOP	12
F11-ISO	13
F11-SAE	14
Installation dimensions CETOP	
F11-005	15
F11-006, -010	16
F11-012	18
F11-014	20
F11-019	22
Installation dimensions ISO	
F11-006, -010	24
F11-012	26
F11-014	28
Installation dimensions SAE	
F11-006, -010	30
F11-012	32
F11-014	34
F11-019	36

Frame size F11	-005	-006	-010	-012	-014	-019
Displacement [cm ³ /rev]	4.9	6.0	9.8	12.5	14.3	19.0
Operating pressure						
max intermittent ¹⁾ [bar]	420	420	420	420	420	420
max continuous [bar]	350	350	350	350	350	350
Motor operating speed [rpm]						
max intermittent ¹⁾	14 000	11 200	11 200	10 300	9 900	8 900
max continuous ³⁾	12 800	10 200	10 200	9 400	9 000	8 100
min continuous	50	50	50	50	50	50
Max pump selfpriming speed ²⁾						
L or R function; max [rpm]	4 600	–	4 200	3 900	3 900	3 500
Motor input flow						
max intermittent ¹⁾ [l/min]	69	67	110	129	142	169
max continuous [l/min]	63	61	100	118	129	154
Drain temperature ³⁾ , max [°C]	115	115	115	115	115	115
min [°C]	-40	-40	-40	-40	-40	-40
Theoretical torque at 100 bar [Nm]	7.8	9.5	15.6	19.8	22.7	30.2
Mass moment of inertia						
(x10 ⁻³) [kg m ²]	0.16	0.39	0.39	0.40	0.42	1.1
Weight [kg]	4.7	7.5	7.5	8.2	8.3	11

- 1) Intermittent: max 6 seconds in any one minute.
2) Selfpriming speed valid at sea level. Find more info on page 11
3) See also installation information. Page 69

2

Efficiency

Because of its high overall efficiency, driving a motor/pump from series F11 requires less fuel or electric power. Also, it allows the use of a small reservoir and heat exchanger, which in turn reduce cost, weight, and installation size.

The diagrams to the right show volumetric and mechanical efficiencies of an F11-5 motor.

F11-19 motors can be equipped with Power Boost which in high speed applications can decrease the mechanical losses by up to 15%, see page 7.

Contact Parker Hannifin for efficiency information on a particular F11 frame size that is being considered.

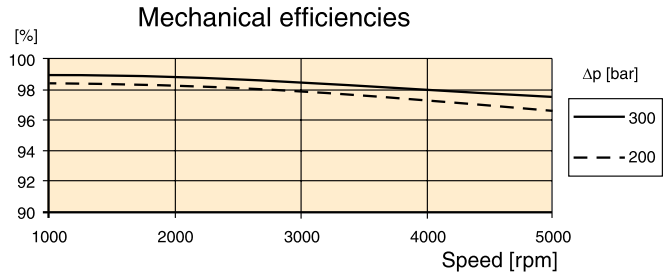
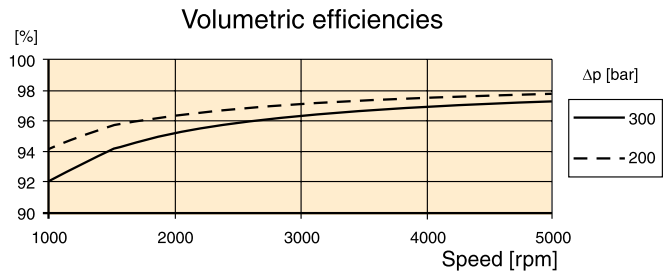

Noise level

Series F11 feature low noise levels from low to high speeds and pressures.

The noise level is measured in a semi-anechoic room, 1 m behind the unit. As an example, the diagram to the right shows the noise level of an F11-005.

The noise level for a particular motor/pump may vary ±2 dB(A) compared to what is shown in the diagram.

NOTE: Noise information for F11/F12 frame sizes are available from Parker Hannifin.

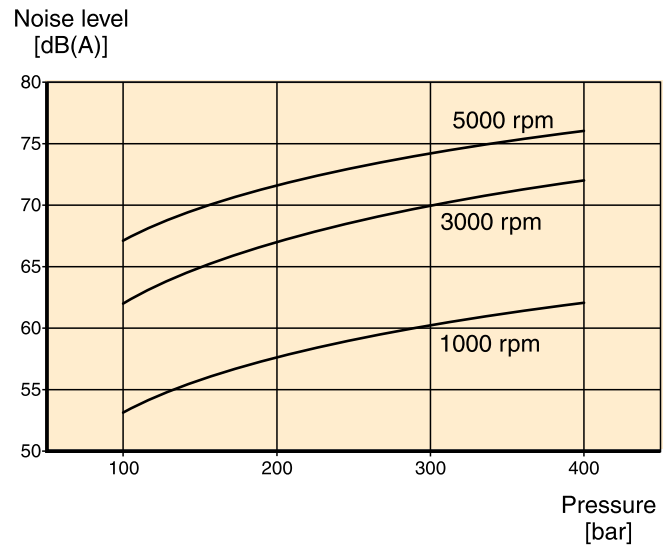

Selfpriming speed and required inlet pressure

Series F11

In pump applications, the F11 with function **L** (counter clockwise rotation) or **R** (clockwise rotation) is normally used. The L and R (pump) provide the highest self priming speeds (see table) as well as the lowest noise level. The **M** and **H** (motor) function can also be used as a pump, in either direction, but at a lower self priming speed.

Operating above the self priming speed (refer to Diagram 1) requires increased inlet pressure. As an example, at least 1.0 bar is needed when operating the F11-19-M as a pump at 3500 rpm. An F11 used as a motor (e.g. in a hydrostatic transmission), may sometimes operate as a pump at speeds above the selfpriming speed; this requires additional inlet pressure. Insufficient inlet pressure can cause pump cavitation resulting in greatly increased pump noise and deteriorating performance.

Function	L or R	M	H
F11-5	4600	3800	3200
F11-6		3100	
F11-10	4200	3100	2700
F11-12	3900	-	3000
F11-14	3900	-	3000
F11-19	3500	2400	2100

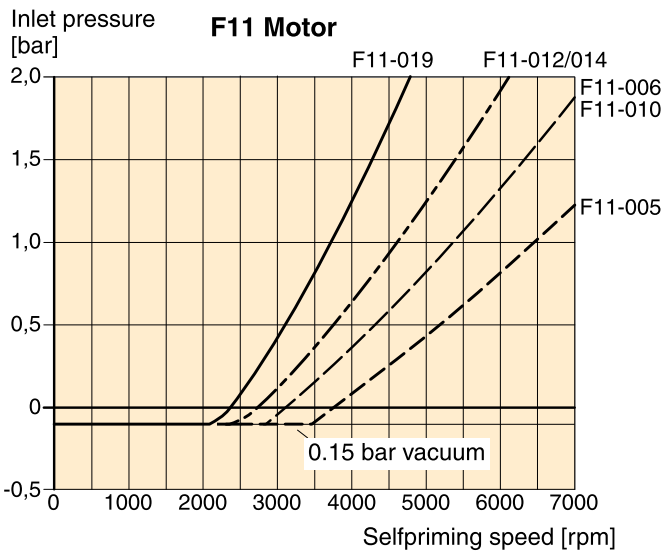
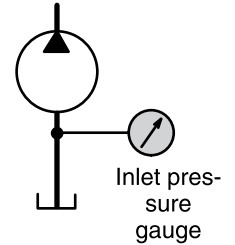

Diagram 1. Min required inlet pressure for Motor.

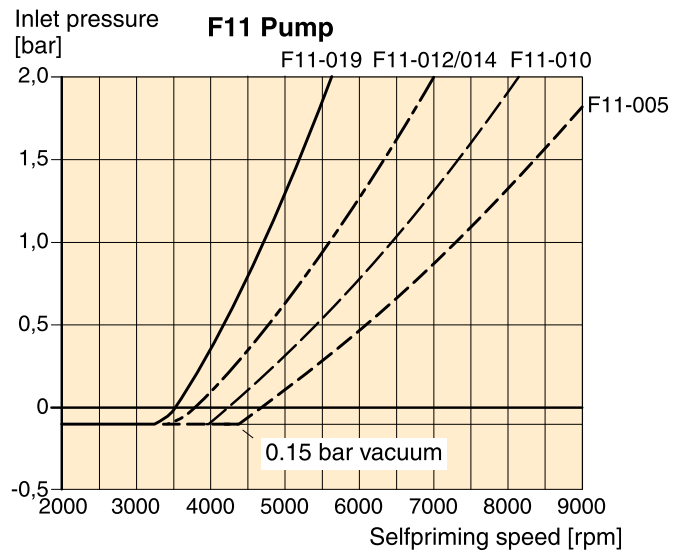
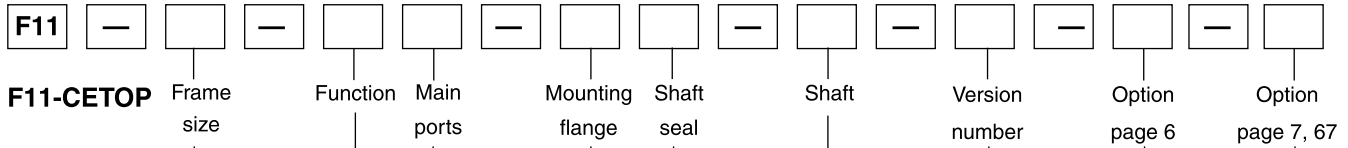

Diagram 2. Min required inlet pressure for Pump.

The inlet pressure can be charged by external pump, pressurized reservoir or using BLA Boost unit
 Find more info about the BLA unit at page 68.



F11-CETOP

Frame size	
Code	Displacem. (cm ³ /rev)
005	4.9
006	6.0
010	9.8
012	12.5
014	14.3
019	19.0

Frame size		5	6	10	12	14	19
Code	Function						
M	Motor	x	x	x	-	-	x
Q	Motor, low noise	x	-	x	x	x	x
S	Motor, high speed	-	-	(x)	(x)	(x)	(x)
H	Motor, high pressure	(x)	-	(x)	-	-	(x)
R	Pump, clockwise rot'n	(x)	-	(x)	(x)	(x)	(x)
L	Pump, counter clockw.	(x)	-	(x)	(x)	(x)	(x)

For other versions, contact Parker Hannifin

Frame size		5	6	10	12	14	19
Code	Main ports						
B	BSP threads	x	x	x	x	x	x
U	SAE, UN threads	(x)	(x)	(x)	(x)	(x)	(x)

Frame size		5	6	10	12	14	19
Code	Mounting flange						
C	CETOP flange	x	x	x	x	x	x
W	Saw motor flange	-	(x)	(x)	(x)	(x)	(x)

x: Available (x): Optional -: Not available

Version number
 (assigned for special versions)

Frame size		5	6	10	12	14	19
Code	Option						
0000	Standard	x	x	x	x	x	x
MUVR	Make up/Anti cavitation valve clockwise rotation	-	-	(x)	(x)	(x)	(x)
MUVL	Make up/Anti cavitation valve counter clockwise rotation	-	-	(x)	(x)	(x)	(x)

Frame size		5	6	10	12	14	19
Code	Shaft*						
K	Metric key	x	x	x	x	x	x
J	Metric key	(x)	(x)	(x)	(x)	-	-
P	Metric key	-	-	-	-	(x)	-
A	Spline, DIN 5480	-	(x)	(x)	(x)	-	-
D	Spline, DIN 5480	x	x	x	x	x	x
S	Spline, SAE	(x)	-	-	-	-	-
V	Tapered shaft	-	(x)	(x)	(x)	(x)	(x)

*See also dimensional drawings on pages 15-23.

Frame size		5	6	10	12	14	19
Code	Shaft seal						
N	NBR, low pressure	(x)	(x)	(x)	-	-	(x)
V	FPM, high pressure, high temperature	x	x	x	x	x	x
S	PTFE, high speed	-	(x)	(x)	(x)	(x)	(x)

Frame size		5	6	10	12	14	19
Code	Option						
00	Standard	x	x	x	x	x	x
P_	Prepared for speed sensor	-	(x)	(x)	(x)	(x)	(x)
B_	Power Boost and Prepared for speed sensor	-	(x)	(x)	(x)	(x)	(x)
_T	Painted Black	(x)	(x)	(x)	(x)	(x)	(x)

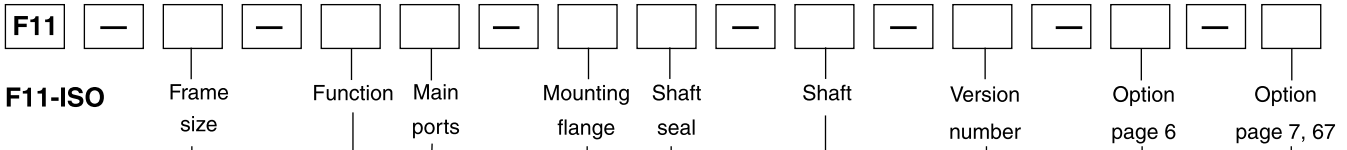

Frame size	
Code	Displacem. (cm ³ /rev)
006	6.0
010	9.8
012	12.5
014	14.3

Version number
 (assigned for special versions)

Frame size		6	10	12	14
Code	Function				
M	Motor	x	x	-	-
Q	Motor, low noise	-	x	x	x
S	Motor, high speed	-	(x)	(x)	(x)
H	Motor, high pressure	-	(x)	-	-
R	Pump, clockwise rot'n	-	(x)	(x)	(x)
L	Pump, counter clockw.	-	(x)	(x)	(x)

Frame size		6	10	12	14
Code	Option				
0000	Standard	x	x	x	x
MUVR	Make up/Anti cavitation valve clockwise rotation	-	(x)	(x)	(x)
MUVL	Make up/Anti cavitation valve counter clockwise rotation	-	(x)	(x)	(x)

For other versions, contact Parker Hannifin

Frame size		6	10	12	14
Code	Main ports				
F	Metric threads	-	x	x	x
B	BSP threads	x	(x)	(x)	(x)
M	Side ports, metric	-	(x)	(x)	(x)

Frame size		6	10	12	14
Code	Shaft*				
K	Metric key	x	x	x	x
J	Metric key	(x)	(x)	(x)	-
P	Metric key	-	-	-	(x)
A	Spline, DIN 5480	(x)	(x)	(x)	-
D	Spline, DIN 5480	x	x	x	x
V	Tapered shaft	(x)	(x)	(x)	(x)

*See also dimensional drawings on pages 25-29.

Frame size		6	10	12	14
Code	Mounting flange				
I	ISO flange	x	x	x	x

Frame size		6	10	12	14
Code	Shaft seal				
N	NBR, low pressure	(x)	(x)	-	-
V	FPM, high pressure, high temperature	x	x	x	x
S	PTFE, high speed	(x)	(x)	(x)	(x)

x: Available (x): Optional -: Not available

Frame size		6	10	12	14
Code	Option				
00	Standard	x	x	x	x
P_	Prepared for speed sensor	(x)	(x)	(x)	(x)
B_	Power Boost and Prepared for speed sensor	(x)	(x)	(x)	(x)
_T	Painted Black	(x)	(x)	(x)	(x)

Ordering codes

**Hydraulic motor/pump
Series F11**



F11-SAE

Frame size	
Code	Displacem. (cm ³ /rev)
006	6.0
010	9.8
012	12.5
014	14.3
019	19.0

Version number
(assigned for special versions)

Frame size		6	10	12	14	19
Code	Option					
0000	Standard	x	x	x	x	x
MUVR	Make up/Anti cavitation valve clockwise rotation	-	(x)	(x)	(x)	(x)
MUVL	Make up/Anti cavitation valve counter clockwise rotation	-	(x)	(x)	(x)	(x)

Frame size		6	10	12	14	19
Code	Function					
M	Motor	x	x	-	-	x
Q	Motor, low noise	-	x	x	x	x
S	Motor, high speed	-	(x)	(x)	(x)	(x)
H	Motor, high pressure	-	(x)	-	-	(x)
R	Pump, clockwise rot'n	-	(x)	(x)	(x)	(x)
L	Pump, counter clockw.	-	(x)	(x)	(x)	(x)

For other versions, contact Parker Hannifin

Frame size		6	10	12	14	19
Code	Main ports					
U	SAE, UN threads	x	x	x	x	x
B	BSP threads	(x)	(x)	(x)	(x)	(x)

Frame size		6	10	12	14	19
Code	Shaft*					
T	SAE key	-	-	-	x	x
S	SAE spline	x	x	x	x	x
K	Metric key	x	x	x	x	x
J	Metric key	(x)	(x)	(x)	-	-
P	Metric key	-	-	-	(x)	-
V	Tapered shaft	(x)	(x)	(x)	(x)	(x)

*See also dimensional drawings on pages 31-37.

Frame size		6	10	12	14	19
Code	Mounting flange					
S	SAE flange	x	x	x	x	x

Frame size		6	10	12	14	19
Code	Shaft seal					
N	NBR, low pressure	(x)	(x)	-	-	(x)
V	FPM, high pressure, high temperature	x	x	x	x	x
S	PTFE, high speed	(x)	(x)	(x)	(x)	(x)

x: Available (x): Optional -: Not available

Frame size		6	10	12	14	19
Code	Option					
00	Standard	x	x	x	x	x
P_	Prepared for speed sensor	(x)	(x)	(x)	(x)	(x)
B_	Power Boost and Prepared for speed sensor	(x)	(x)	(x)	(x)	(x)
_T	Painted Black	(x)	(x)	(x)	(x)	(x)

F11-005
 (CETOP versions)

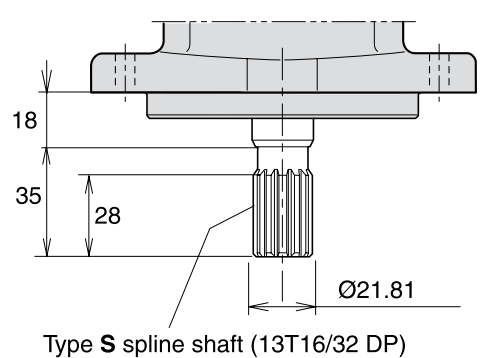
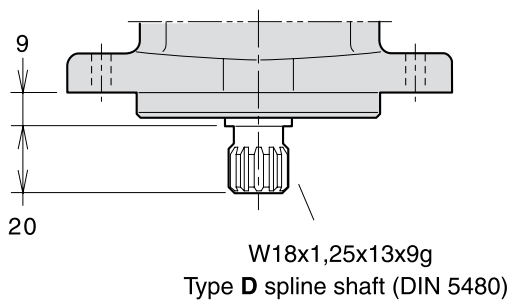
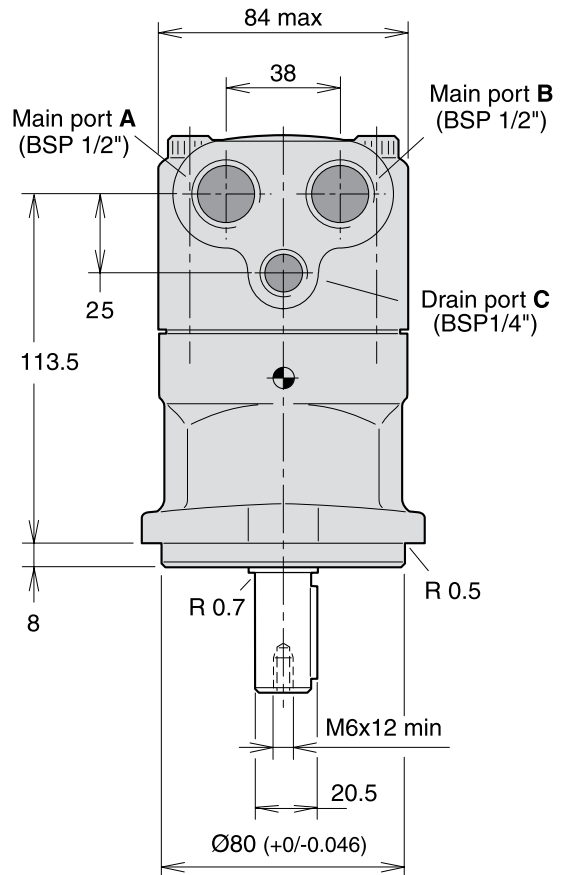
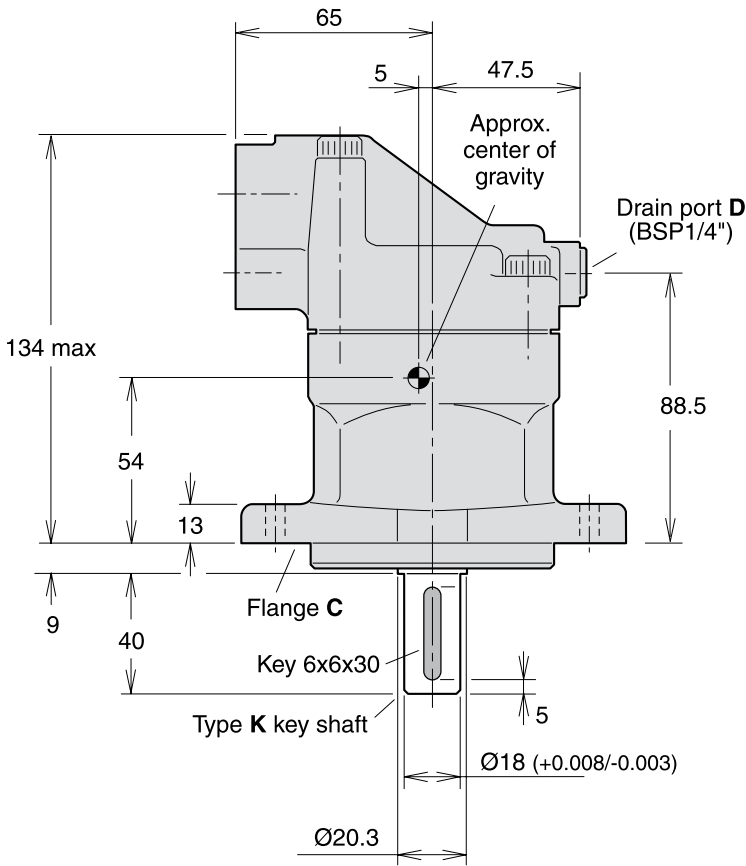
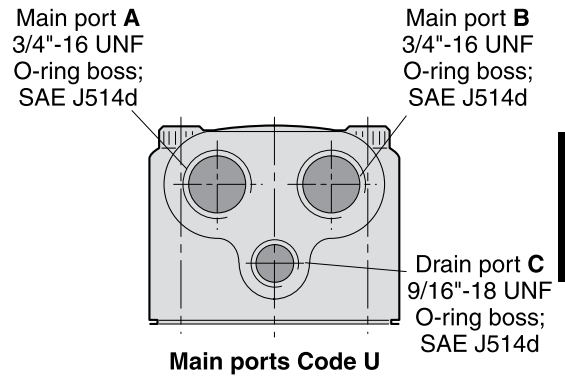
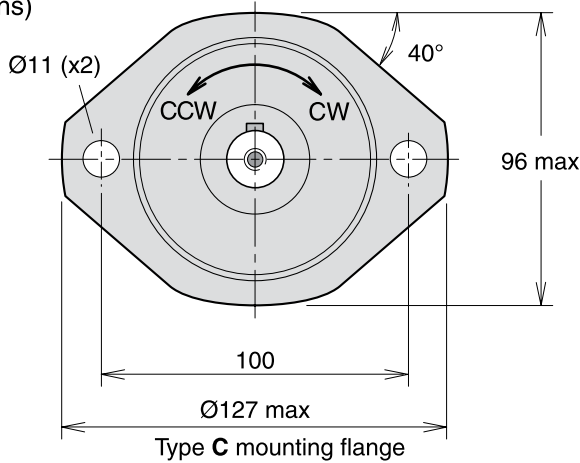

F11-006, -010
 (CETOP versions)

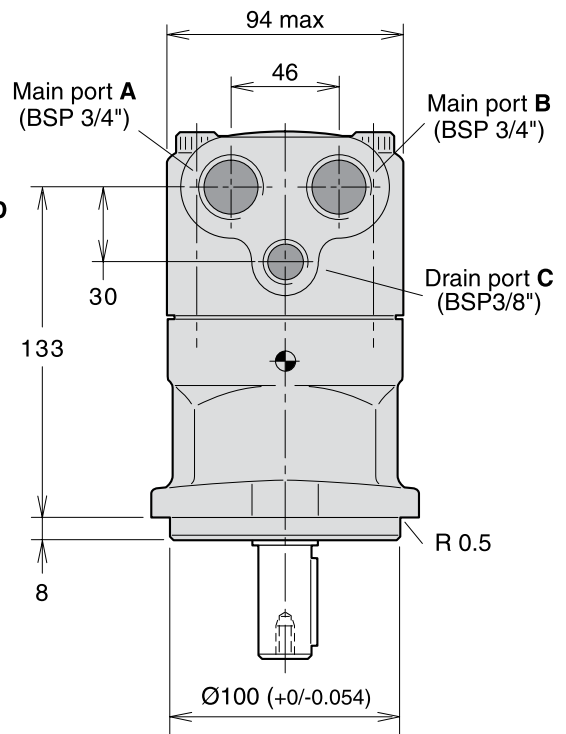
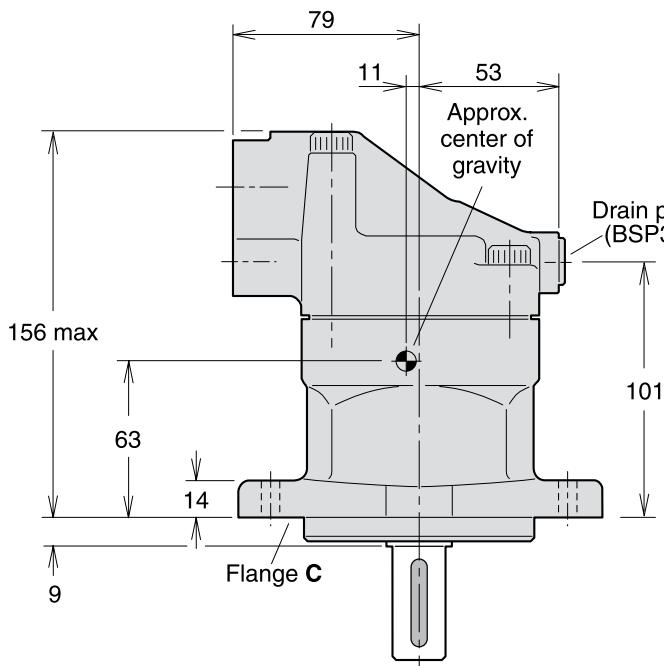
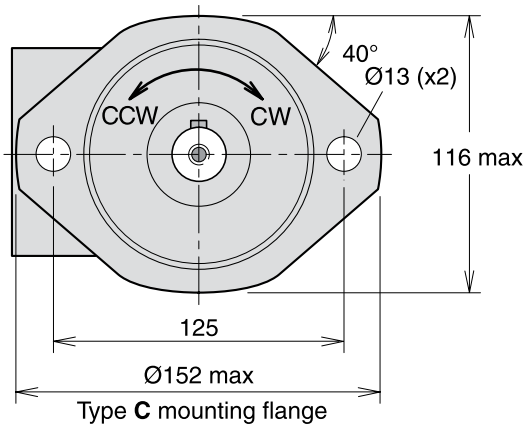

F11-006, -010

(CETOP versions)

Make up/Anti cavitation valve
(MUVL or MUVR optional;
clockwise rotation shown).

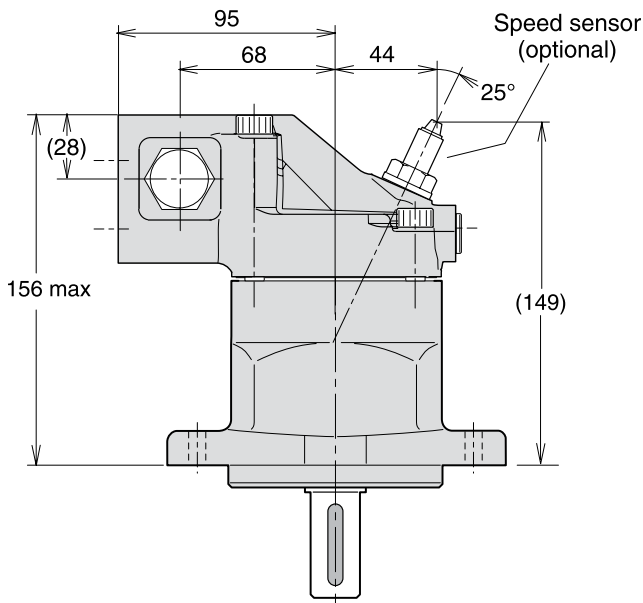
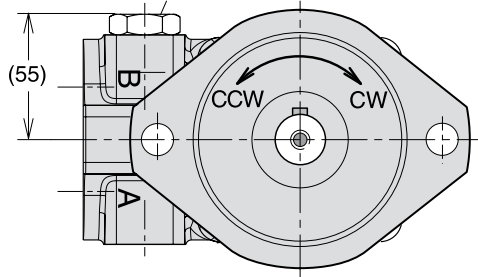

Shaft options

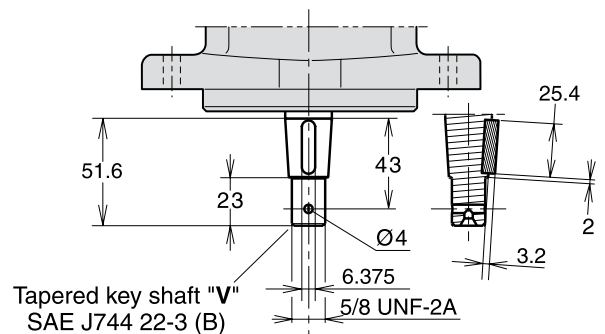
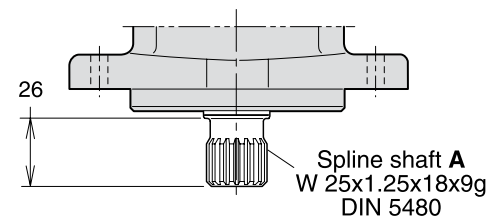
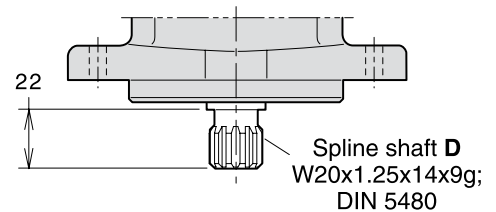
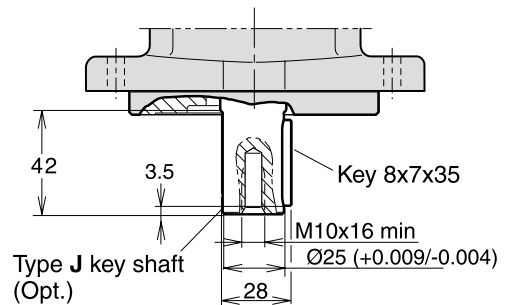
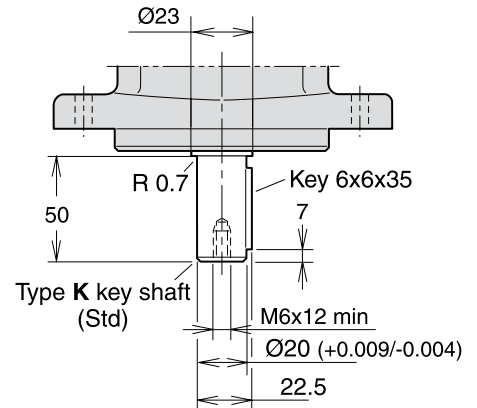

2

F11-012
 (CETOP versions)

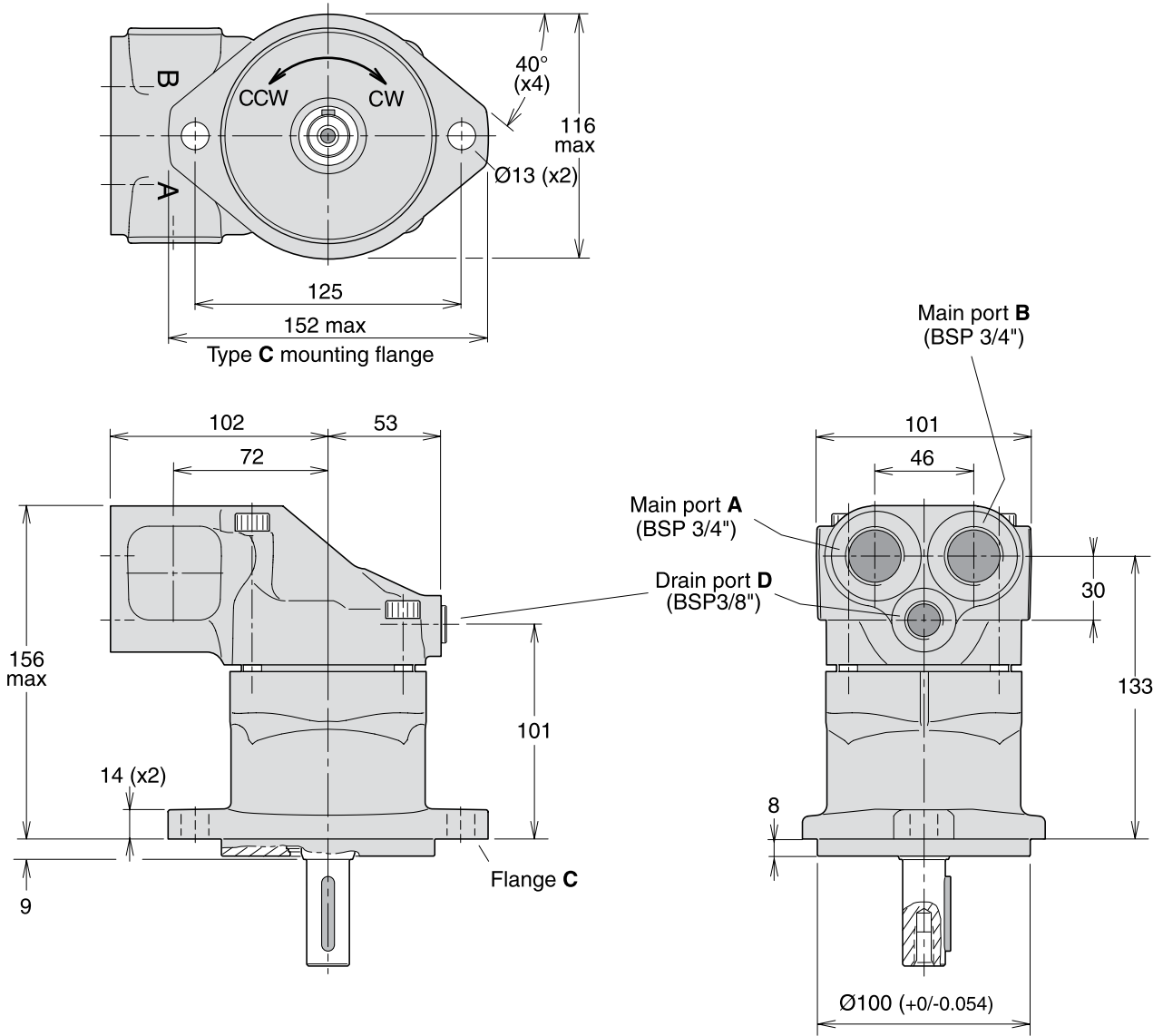

F11-012
 (CETOP versions)

Make up/Anti cavitation valve
 (MUVL or MUVR optional;
 clockwise rotation shown)

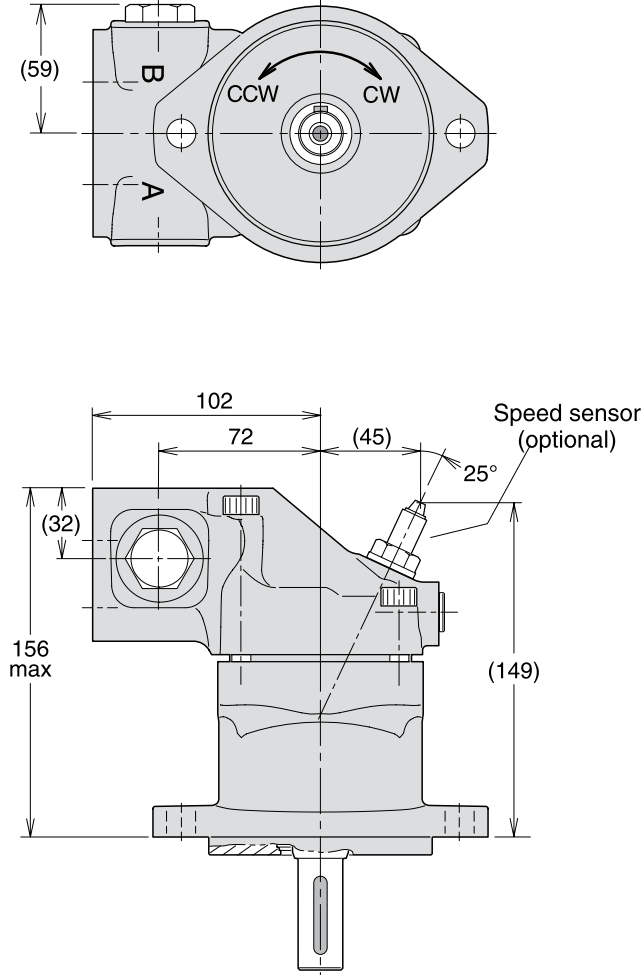

Shaft options

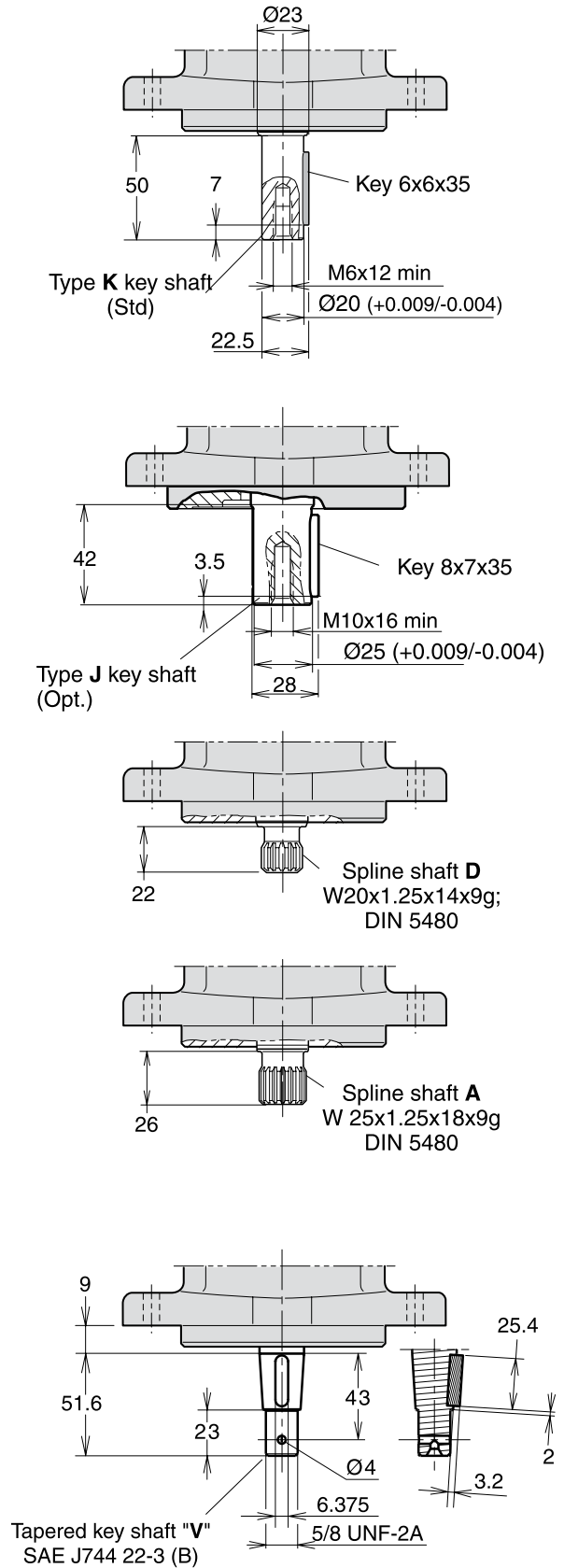

F11-014
 (CETOP versions)

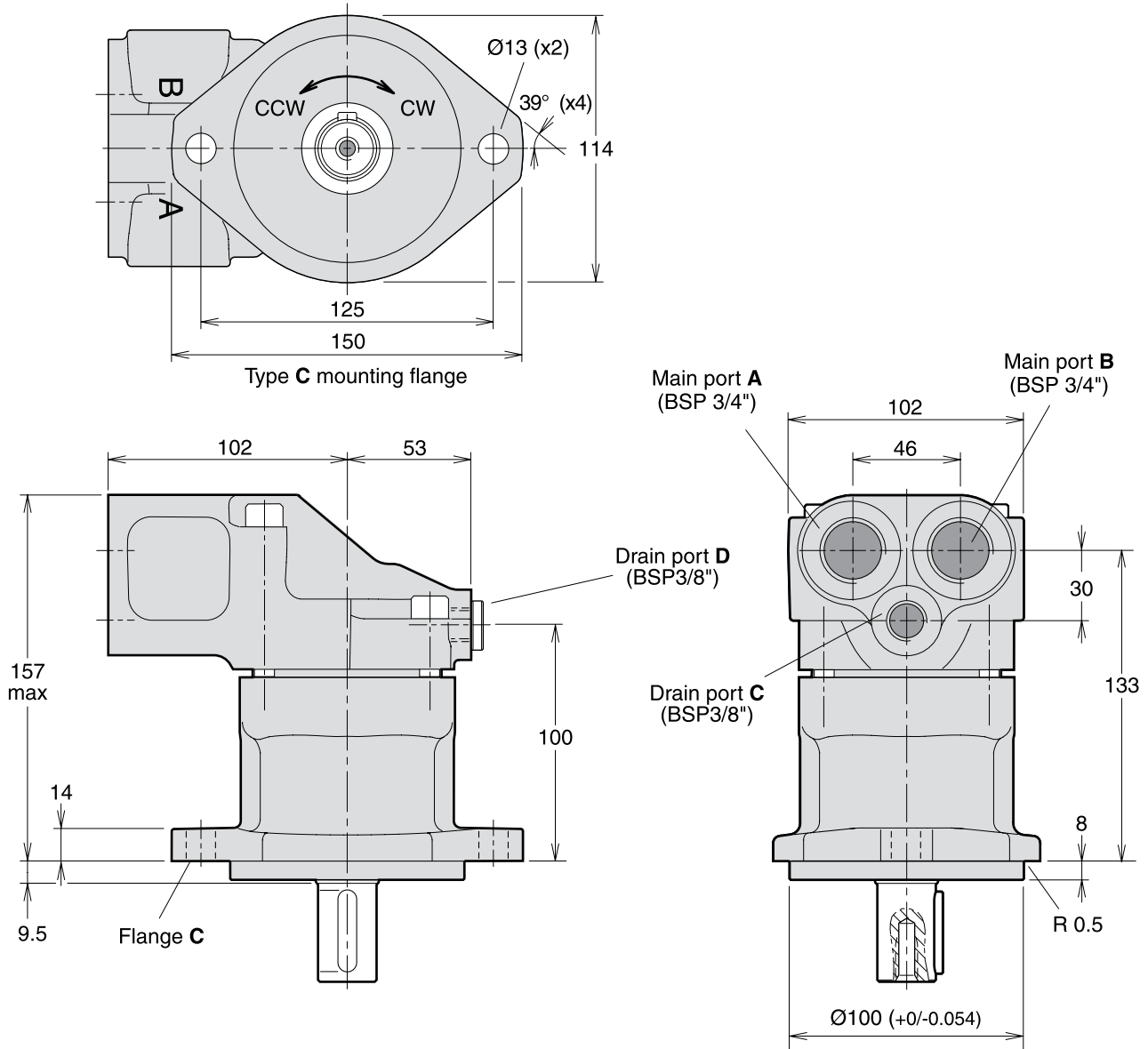

F11-014
 (CETOP versions)

Make up/Anti cavitation valve
 (MUVL or MUVR optional;
 clockwise rotation shown)

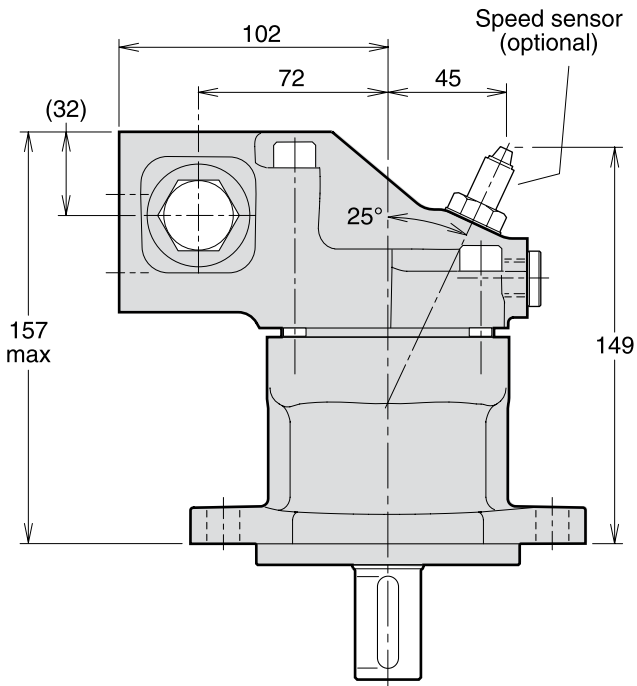
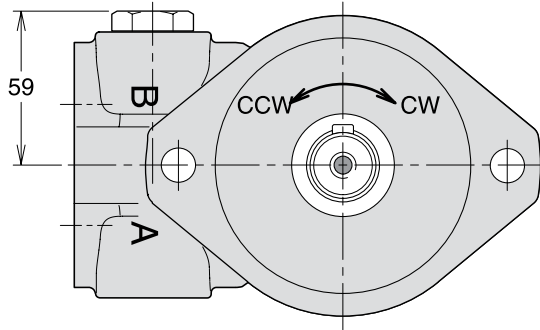

Shaft options

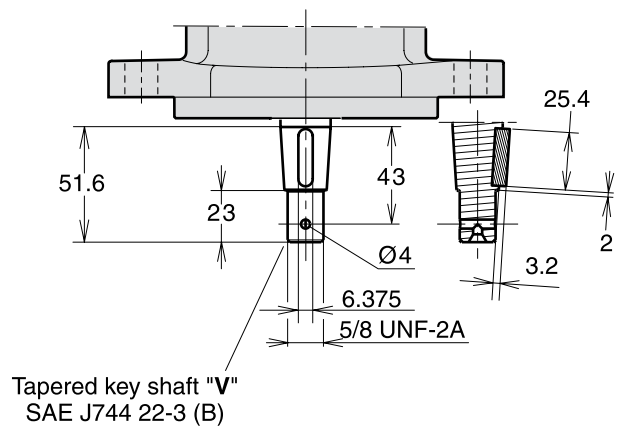
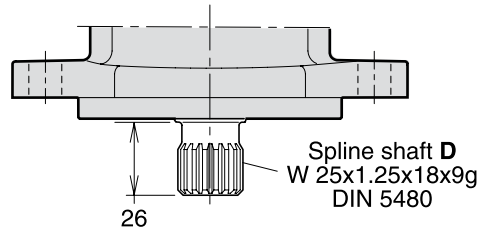
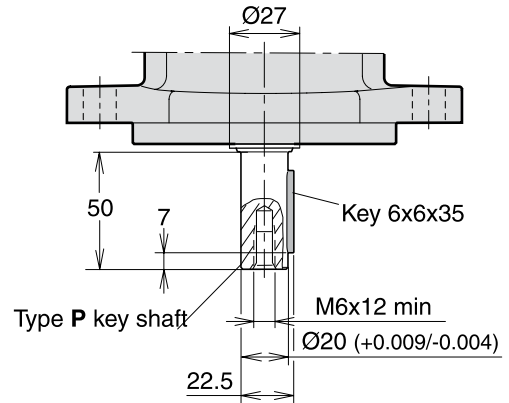
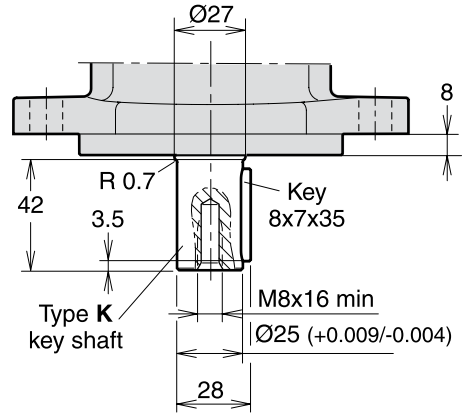

Tapered key shaft "V"
 SAE J744 22-3 (B)



F11-019
 (CETOP version)

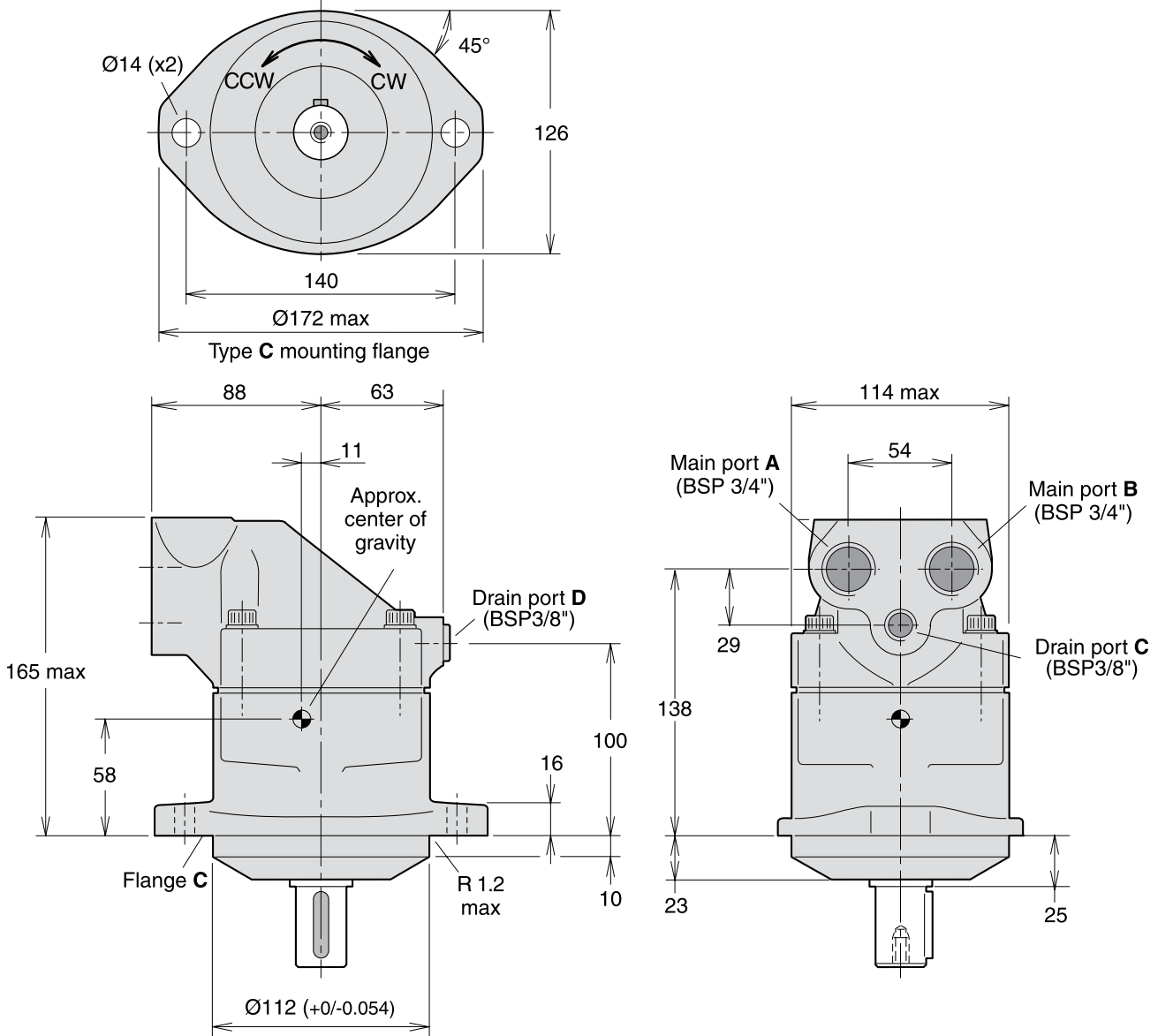

F11-019
 (CETOP version)

Make up/Anti cavitation valve
 (MUVL or MUVR optional;
 clockwise rotation shown)

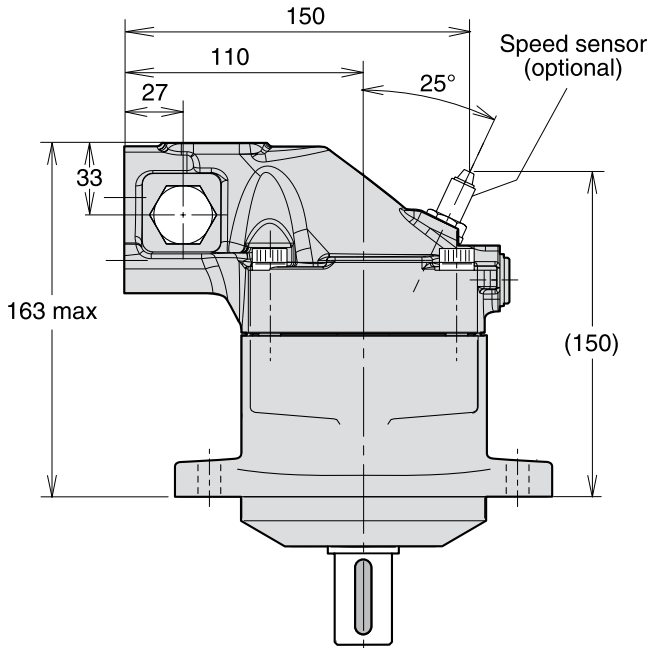
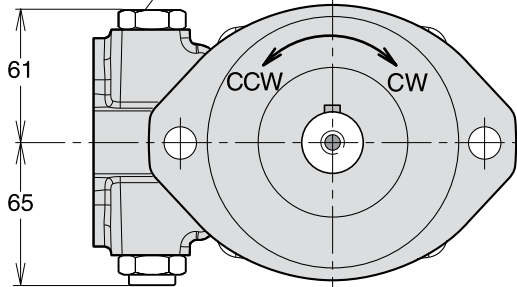

Shaft options

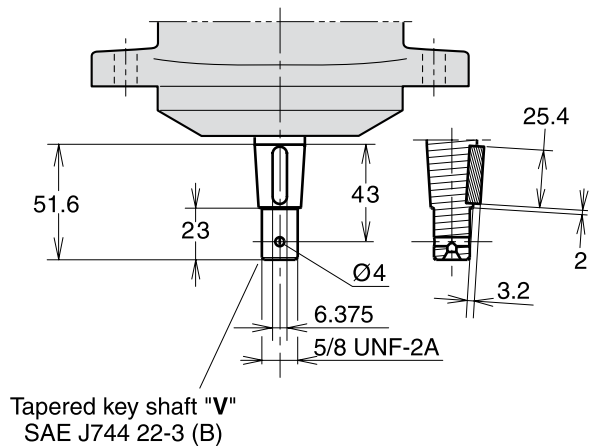
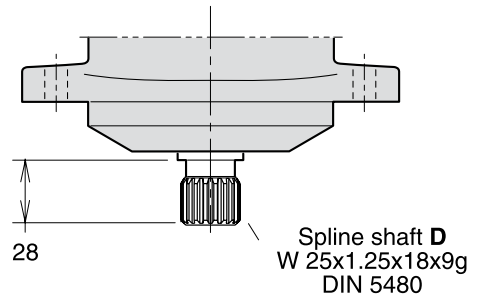
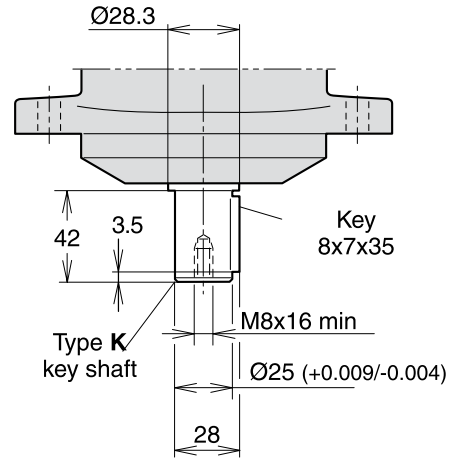

Tapered key shaft "V"
 SAE J744 22-3 (B)

F11-006, -010
 (ISO versions)

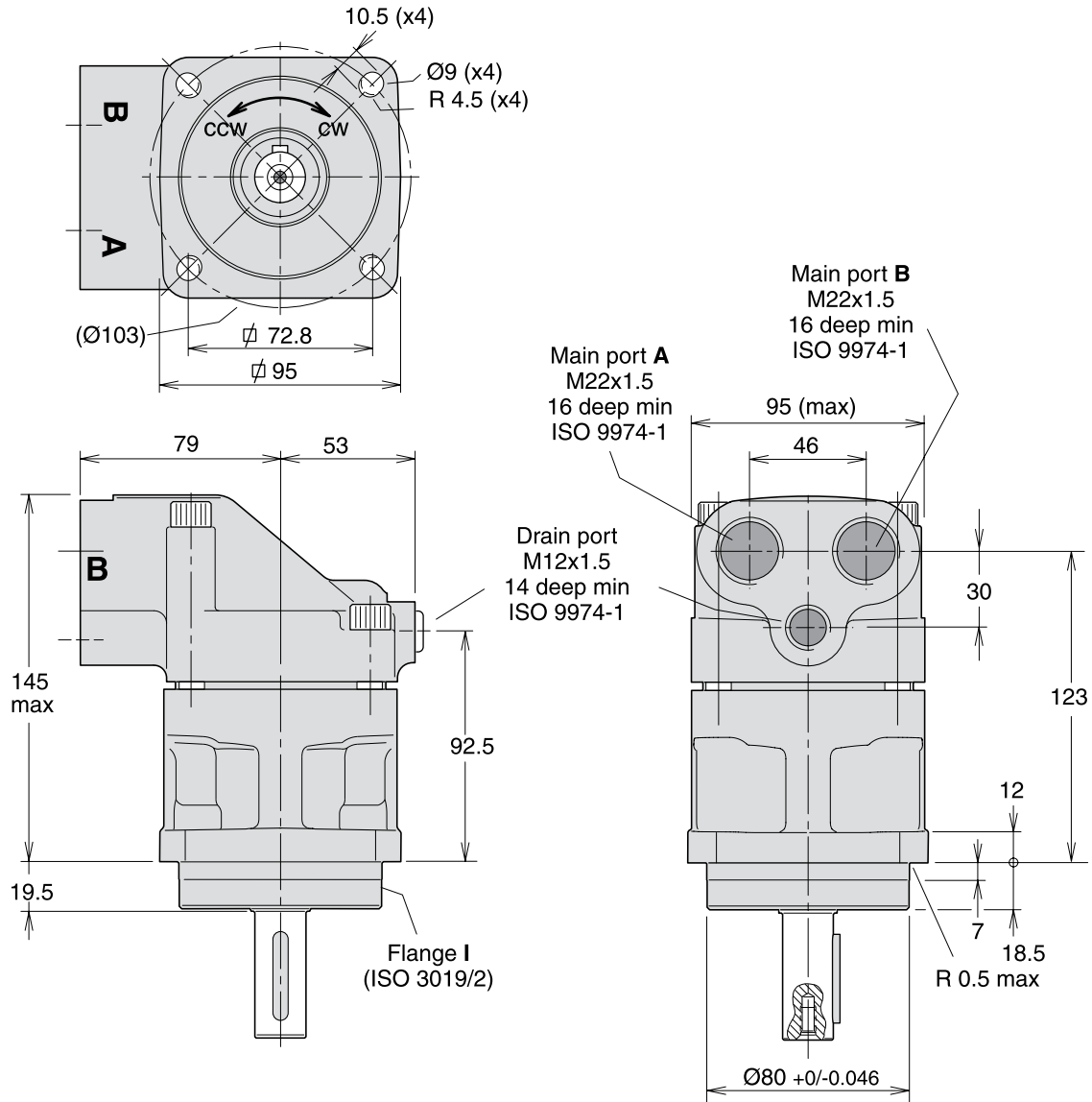

F11-006, -010
(ISO versions)

Make up/Anti cavitation valve
(MUVL or MUVR optional;
clockwise rotation shown)

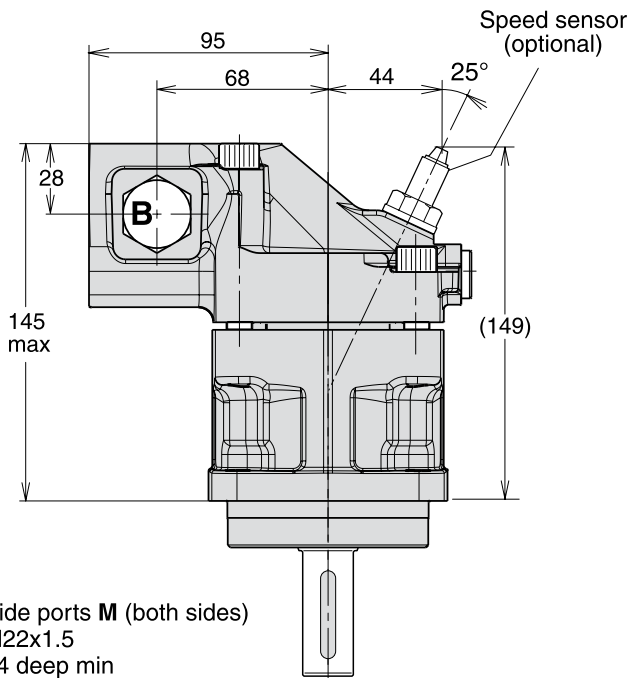
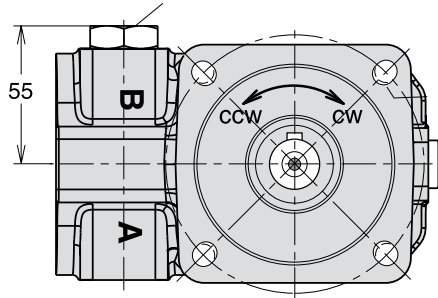

Side ports **M** (both sides)
M22x1.5
14 deep min
ISO 9974-1
Only for F11-010

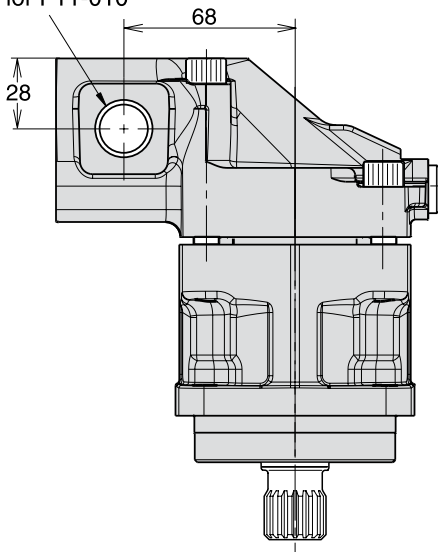

Shaft options

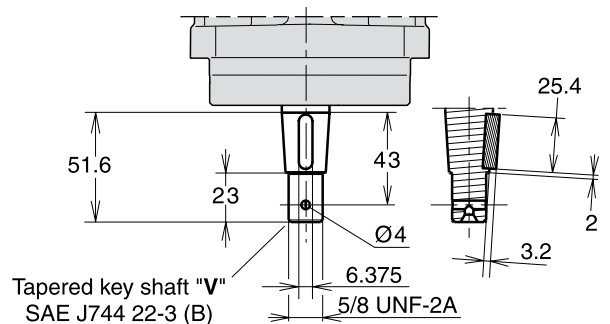
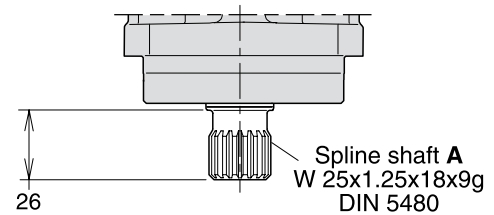
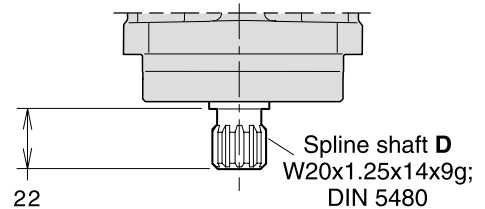
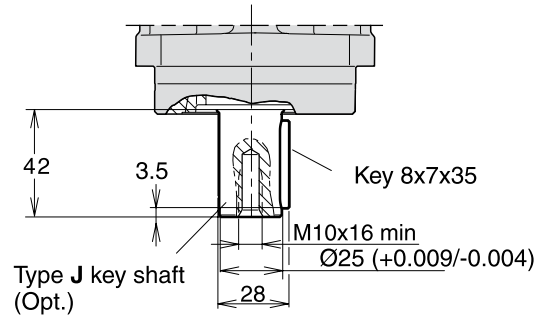
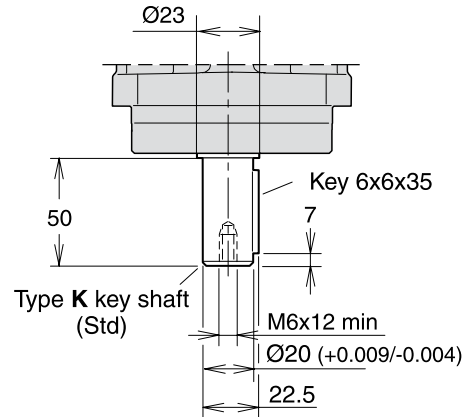

2

F11-012
 (ISO versions)

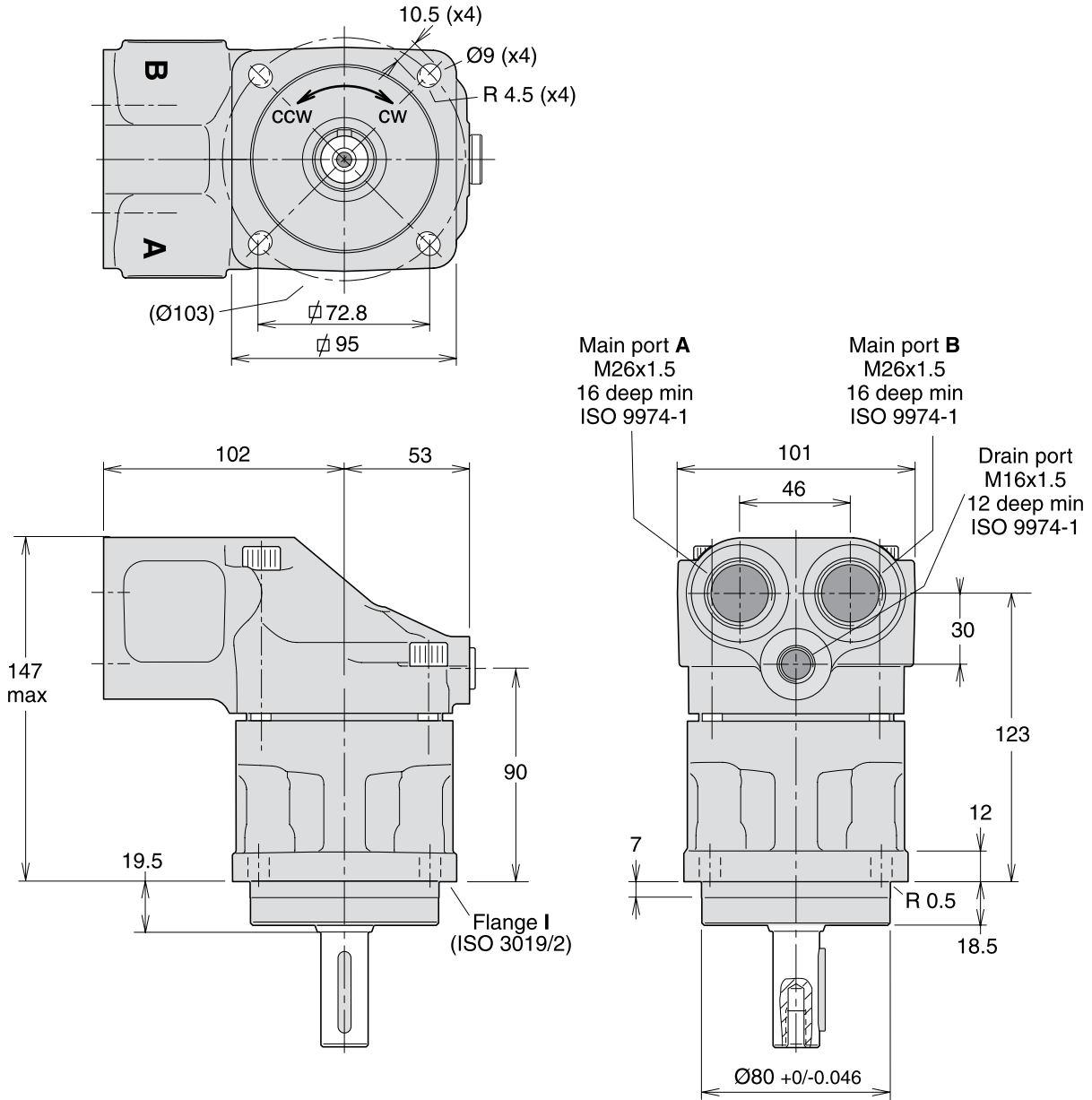

F11-012
(ISO versions)

Make up/Anti cavitation valve
(MUVL or MUVR optional;
clockwise rotation shown)

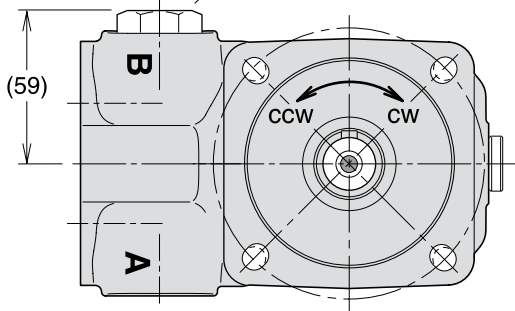

Speed sensor
(optional)

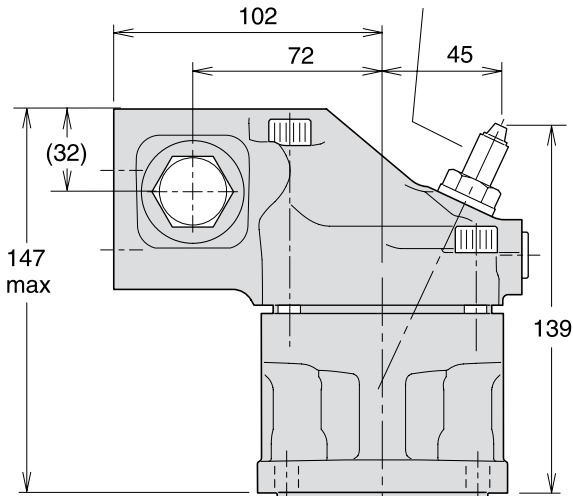

Side ports **M** (both sides)
M22x1.5
14 deep min
ISO 9974-1

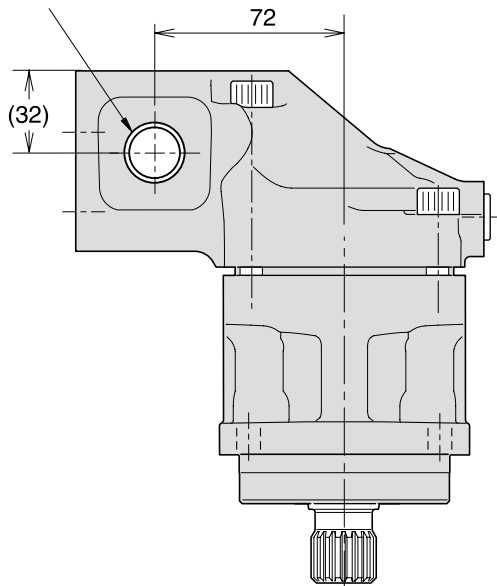

Shaft options

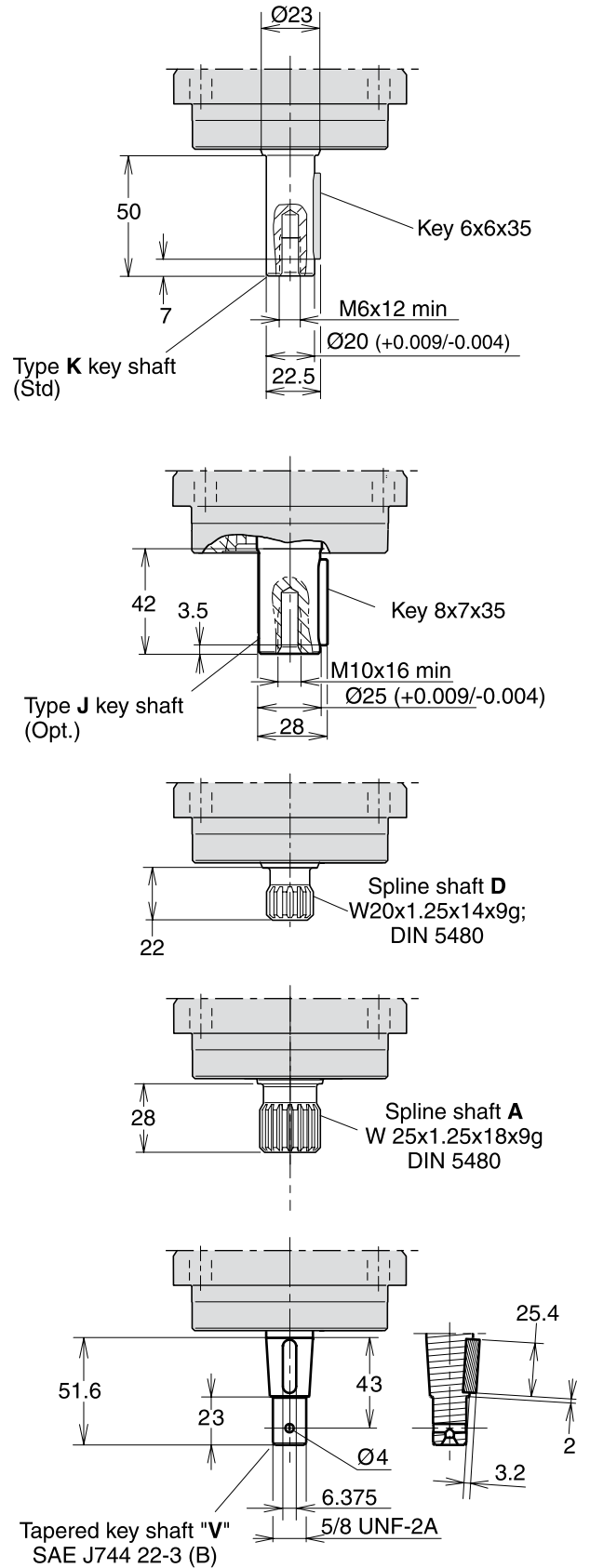

F11-014
 (ISO versions)

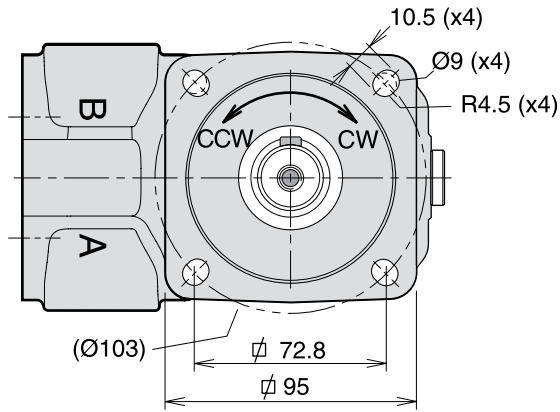

Type I mounting flange (ISO 3019/2)

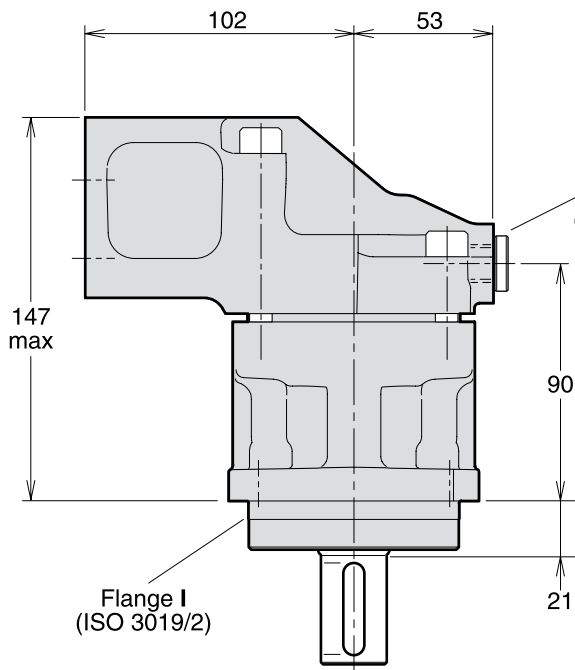

Drain port D M16x1.5
 (depth 12; ISO 9974-1)

Drain port C M16x1.5
 (depth 12; ISO 9974-1)

Flange I
 (ISO 3019/2)

Main port A
 M26x1.5
 16 deep min
 ISO 9974-1

Main port B
 M26x1.5
 16 deep min
 ISO 9974-1

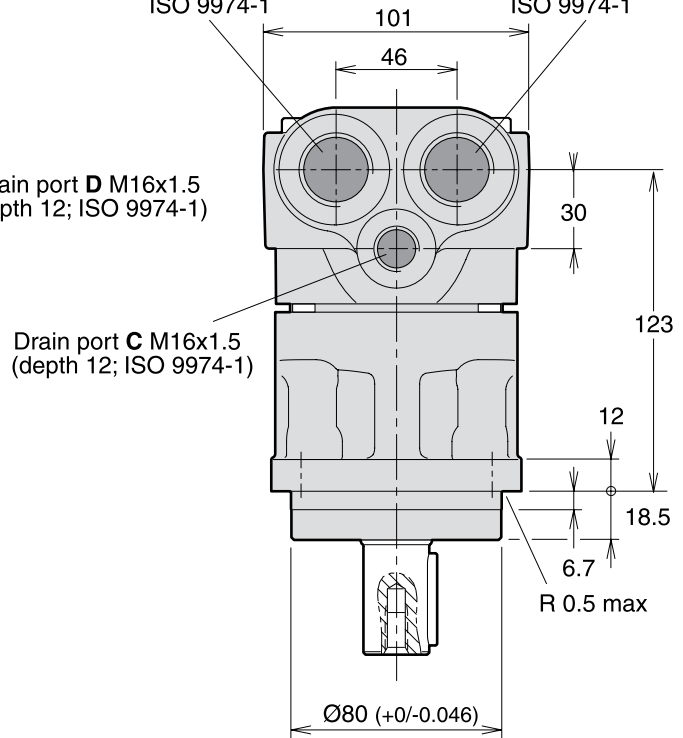

F11-014

(ISO versions)

Make up/Anti cavitation valve
(MUVL or MUVR optional;
clockwise rotation shown)

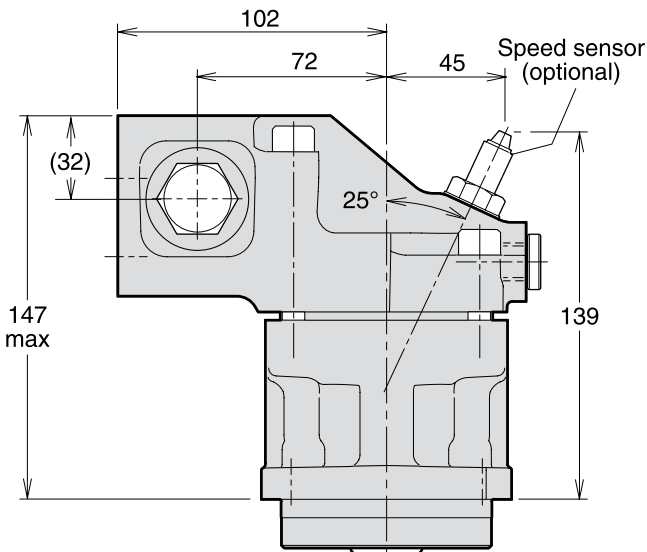
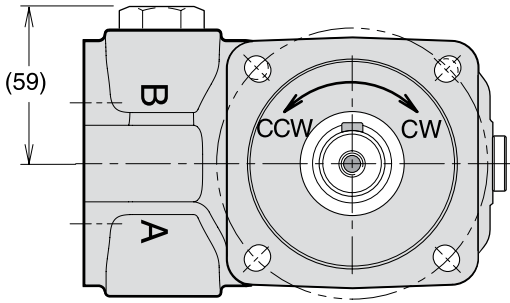

Side ports M (both sides)
M22x1.5
14 deep min
ISO 9974-1

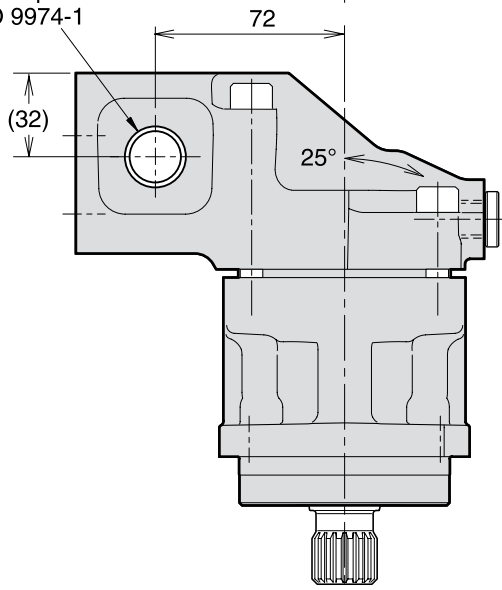

Shaft options

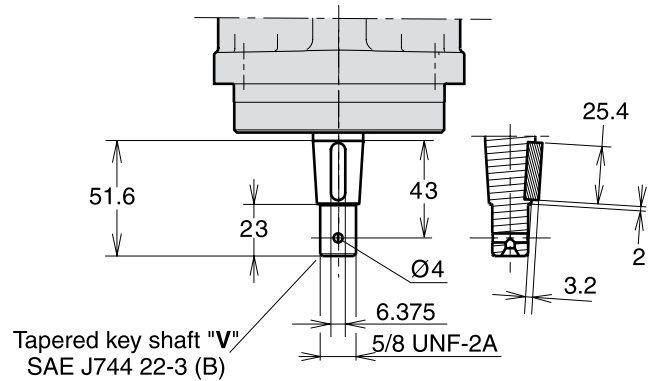
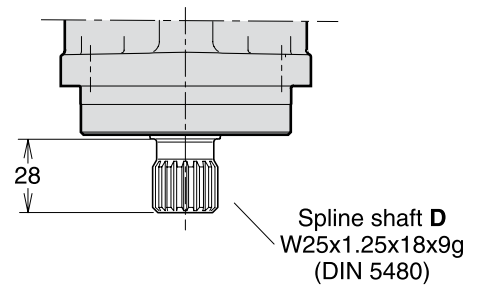
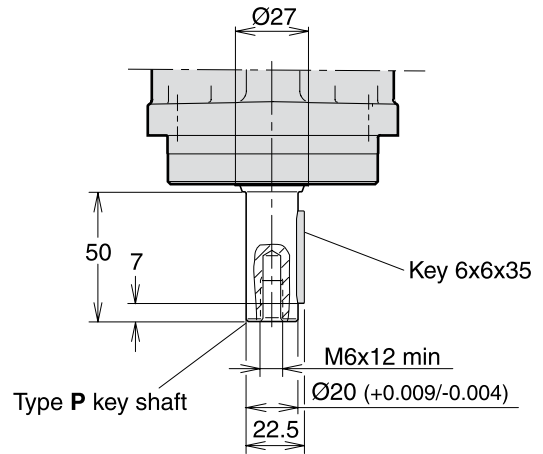
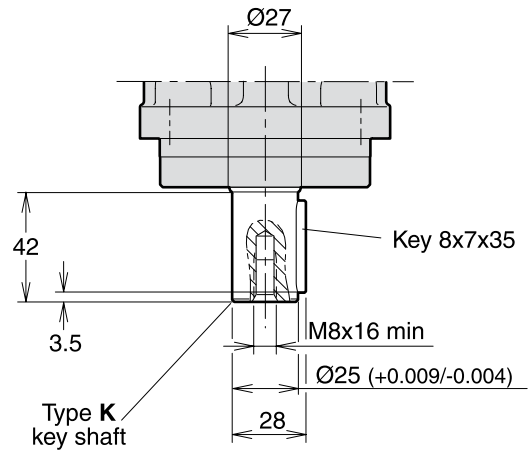

2

F11-006, -010
 (SAE versions)

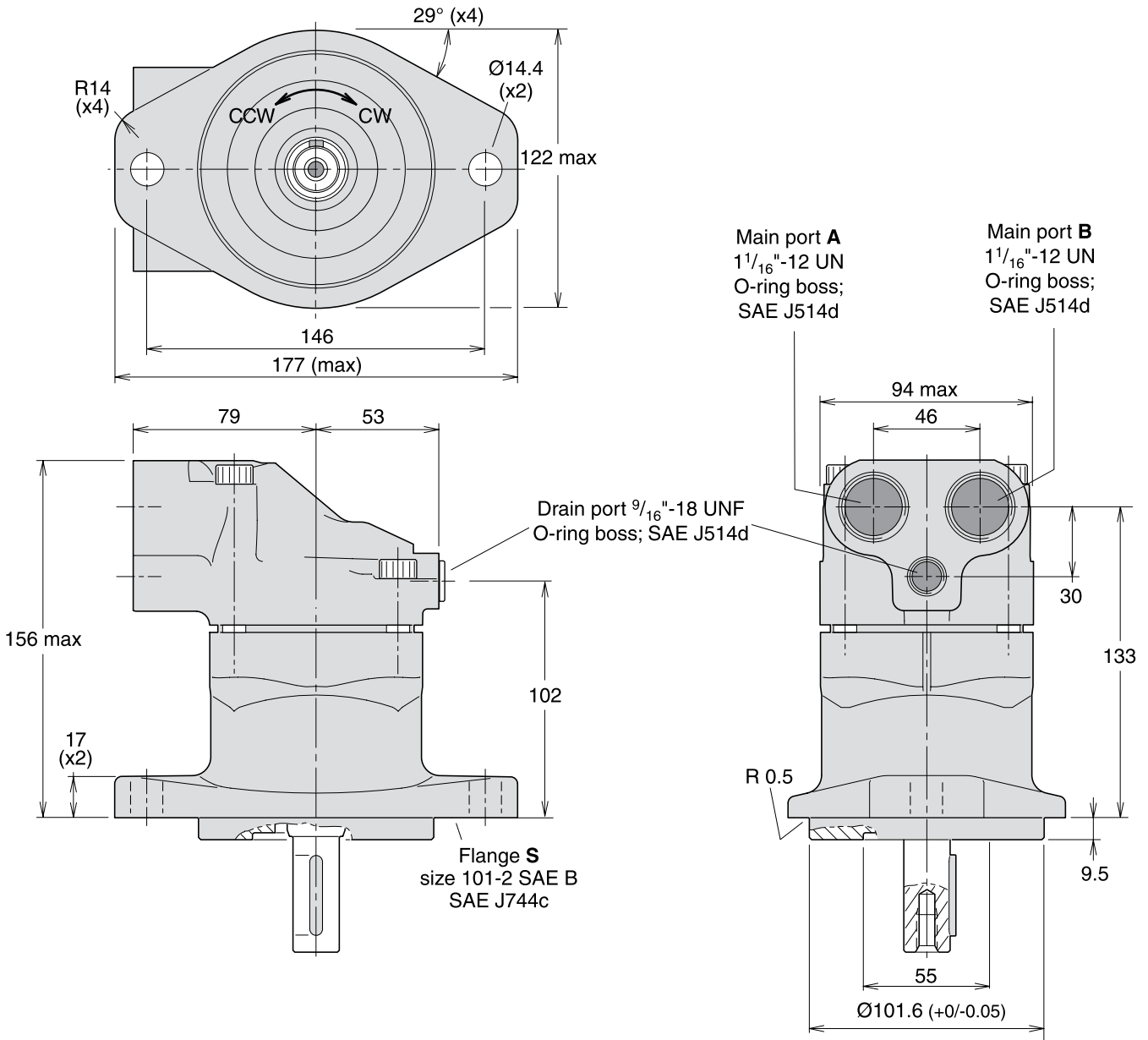

F11-006, -010
(SAE versions)

Make up/Anti cavitation valve
(MUVL or MUVR optional;
clockwise rotation shown)

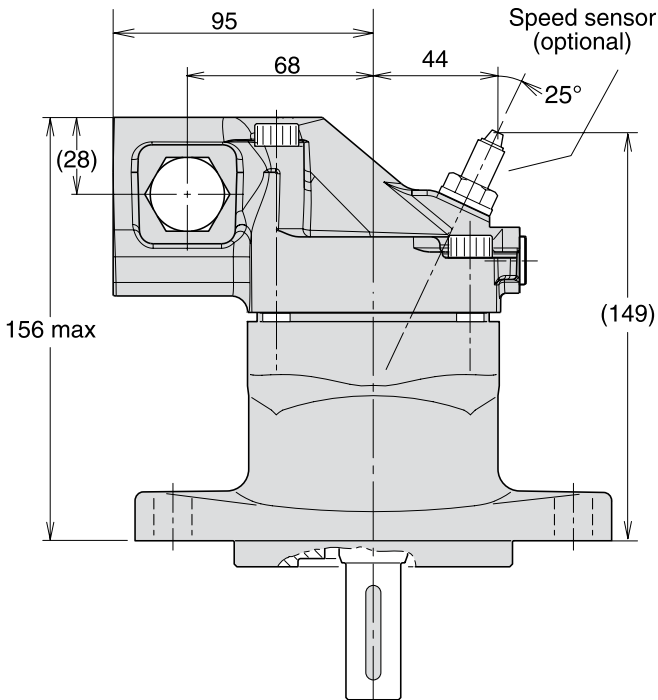
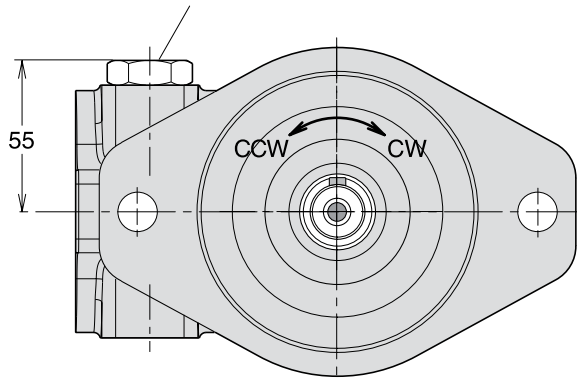

Shaft options

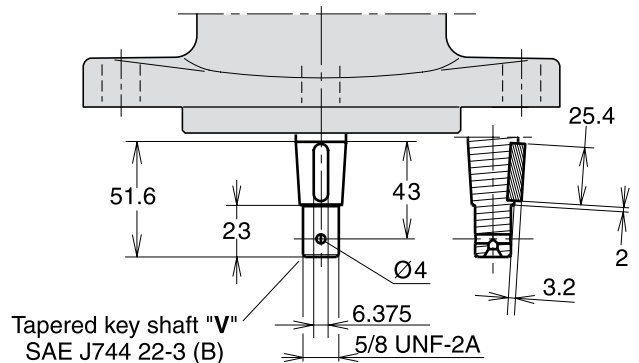
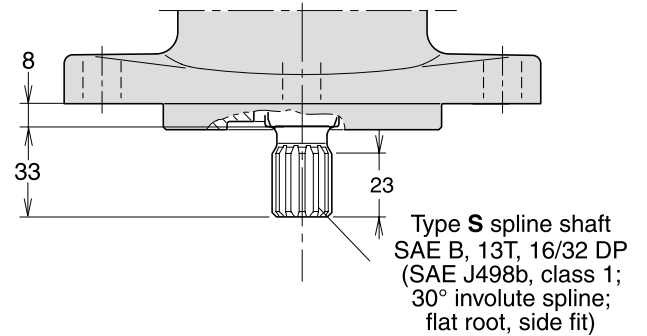
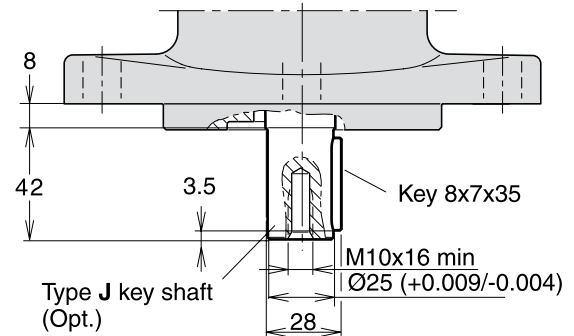
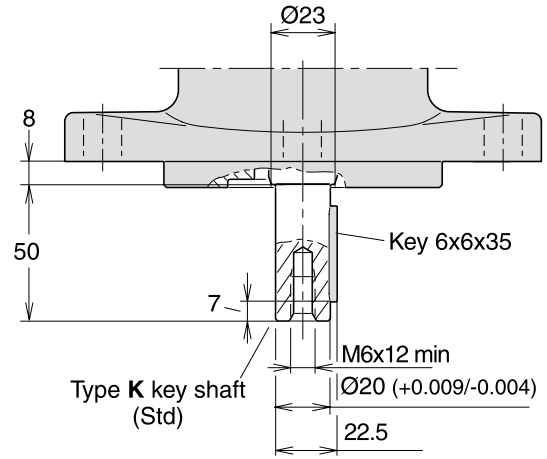

2

F11-012
 (SAE versions)

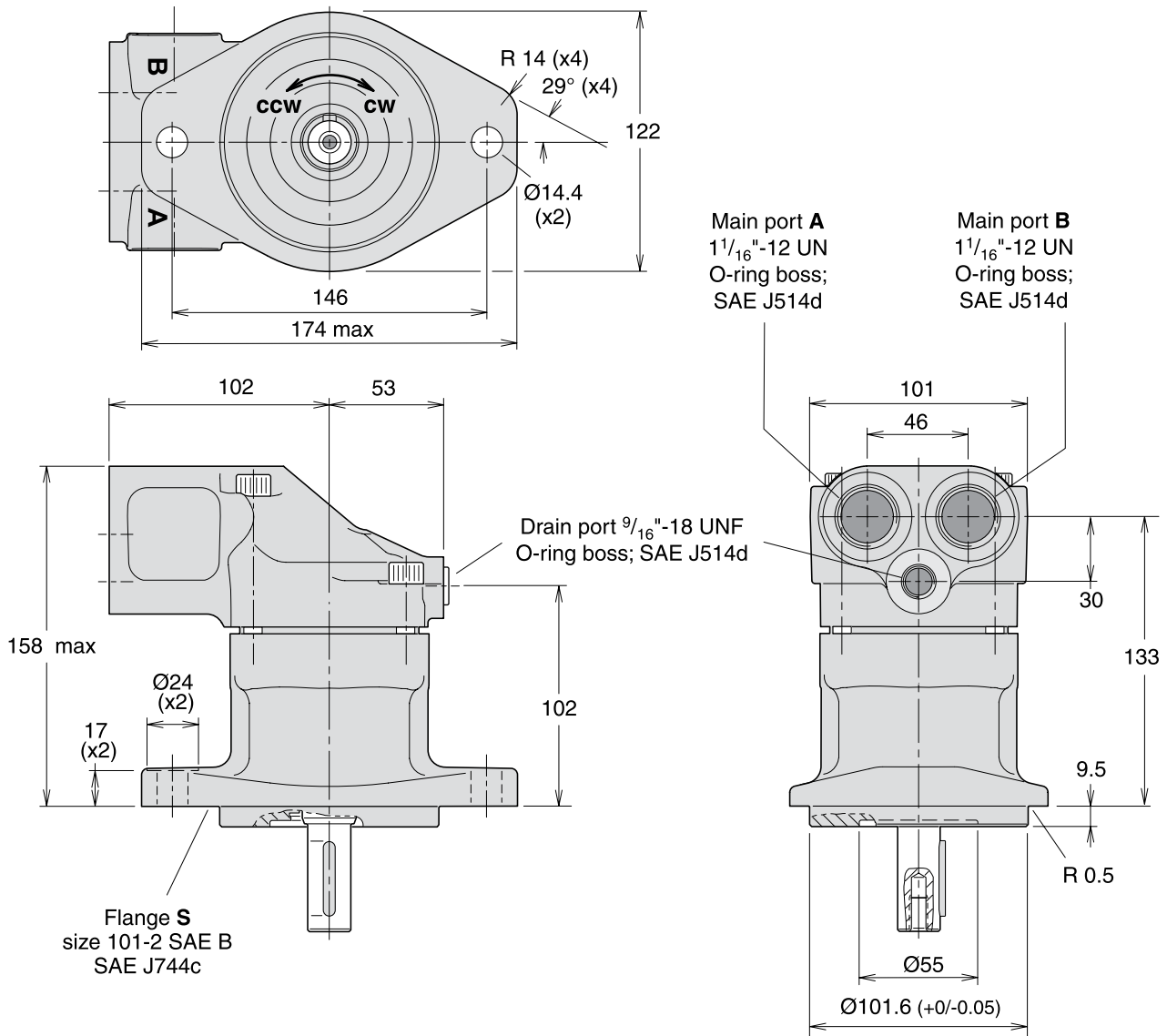

F11-012
 (SAE versions)

Make up/Anti cavitation valve
 (MUVL or MUVR optional;
 clockwise rotation shown)

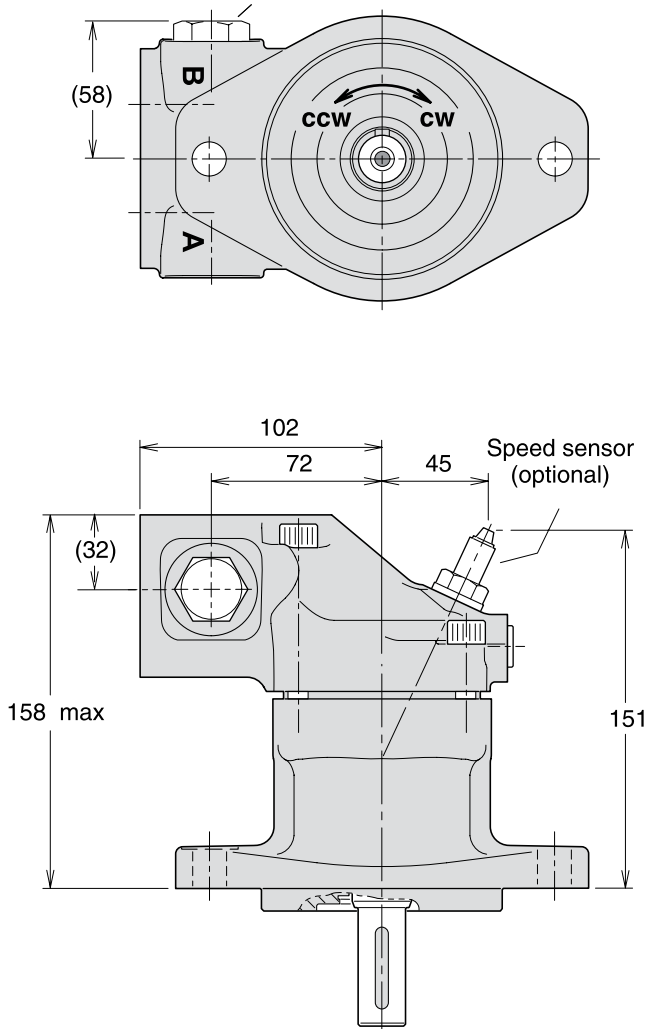

Shaft options

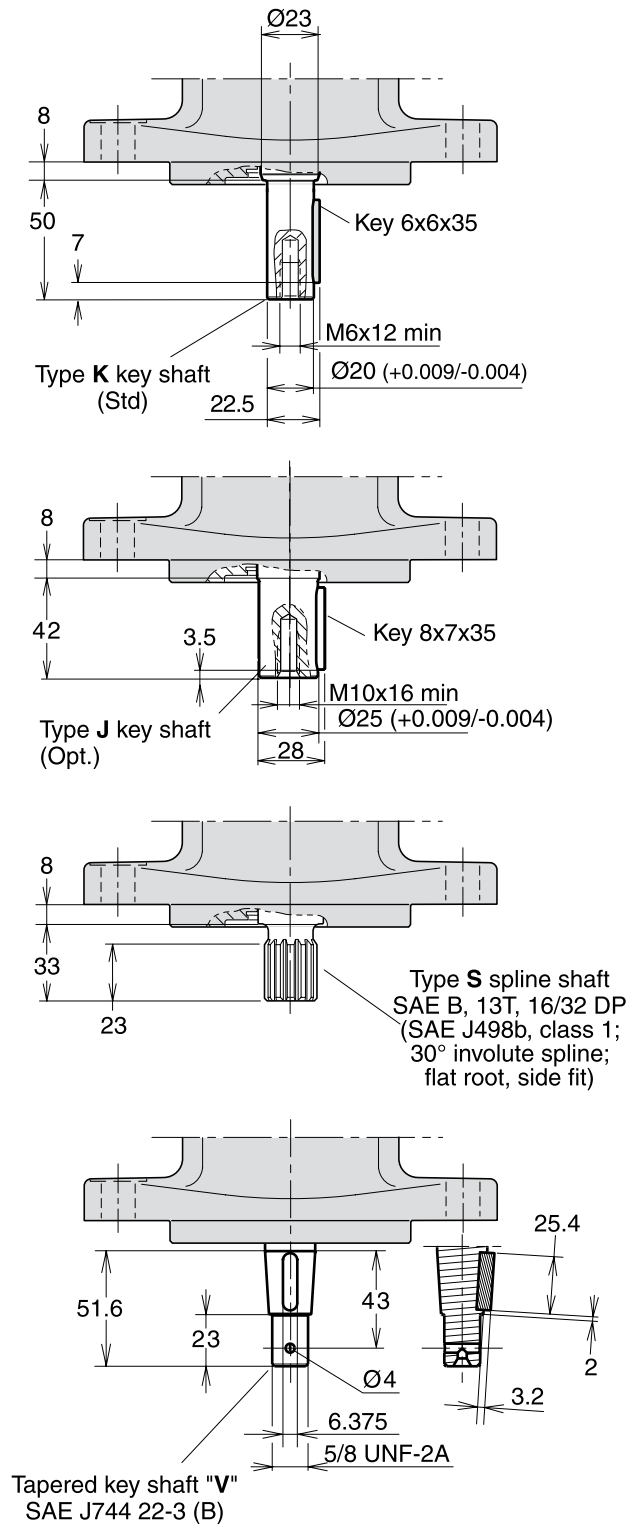

2

F11-014
 (SAE versions)

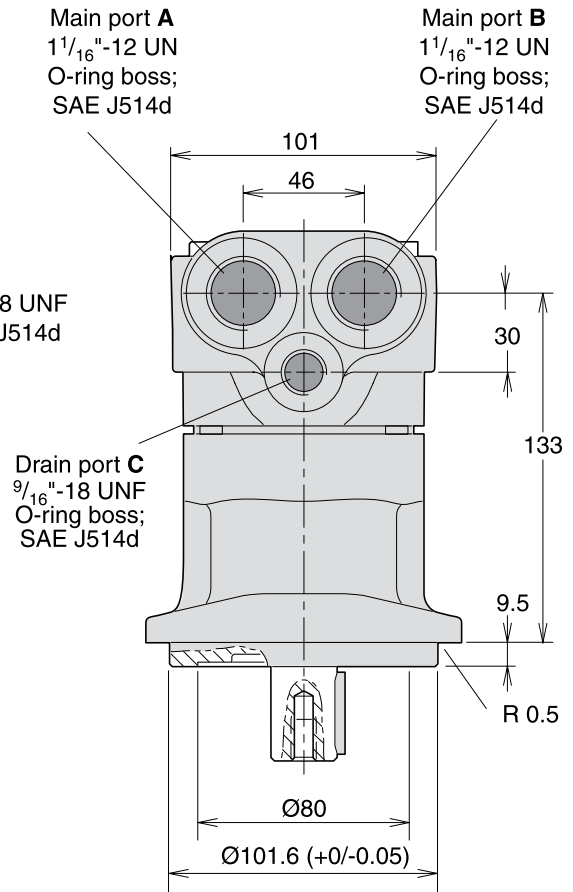
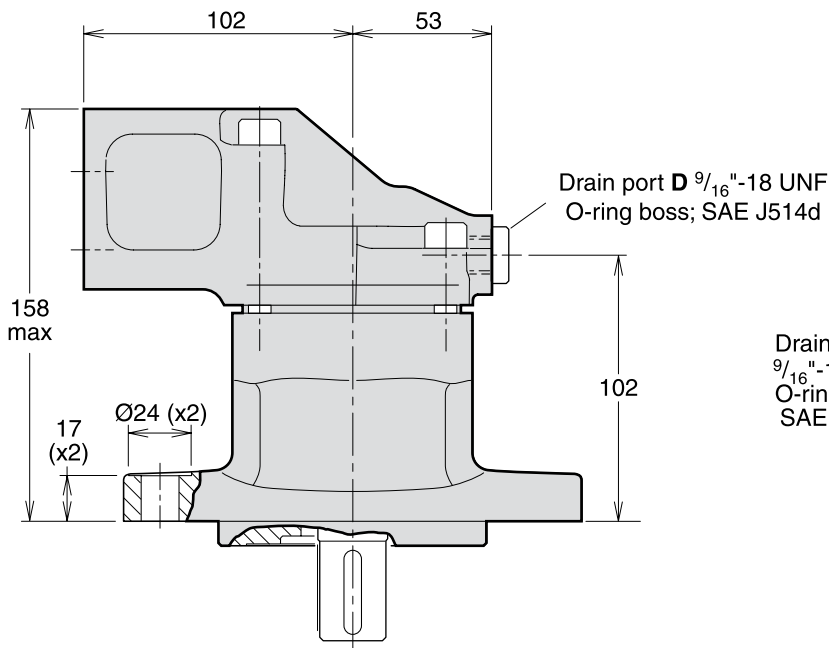
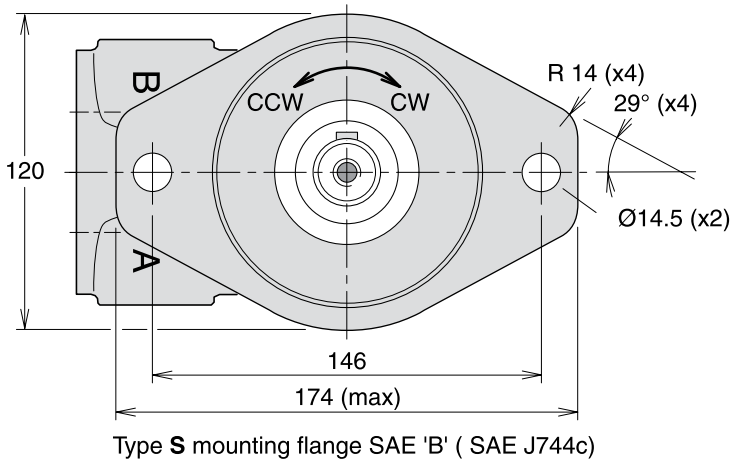

F11-014
 (SAE versions)

Make up/Anti cavitation valve
 (MUVL or MUVR optional;
 clockwise rotation shown)

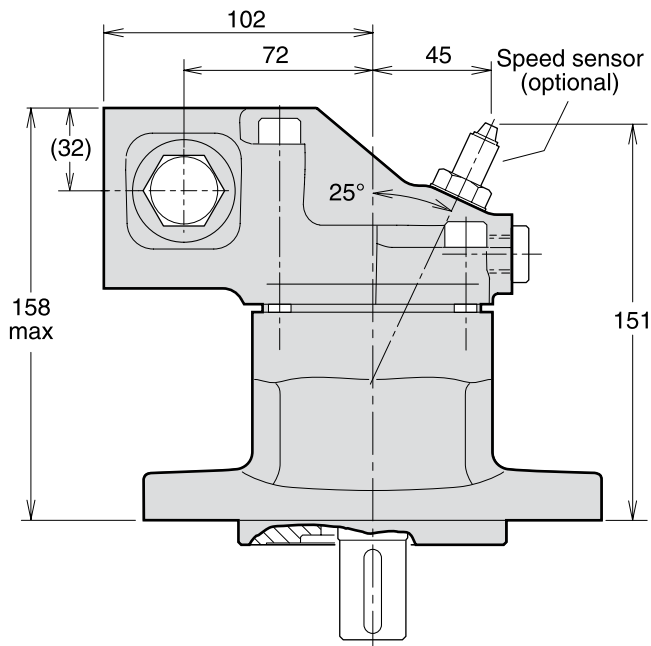
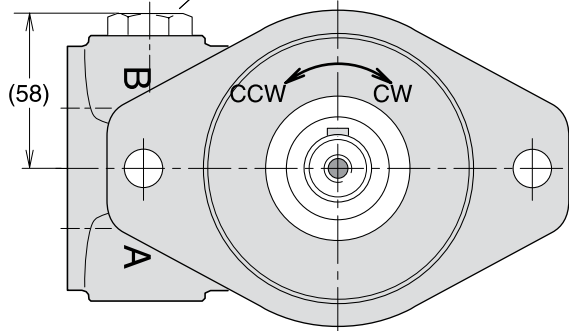

Shaft options

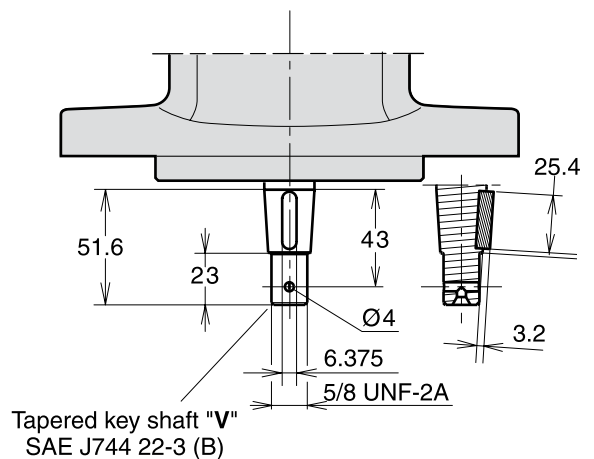
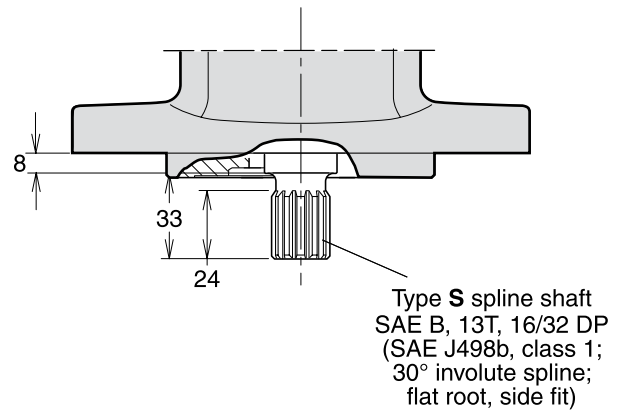
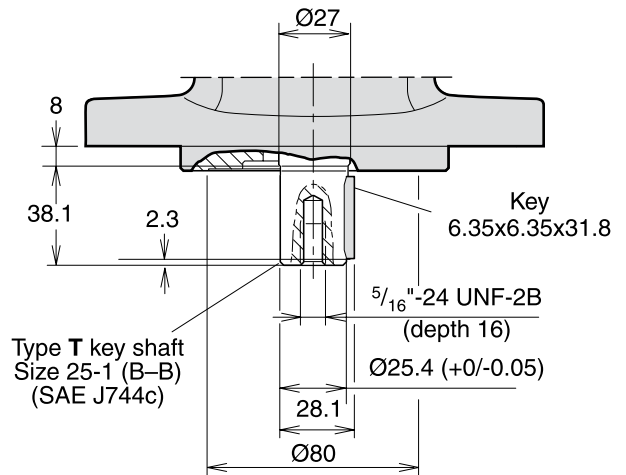

2

F11-019
 (SAE version)

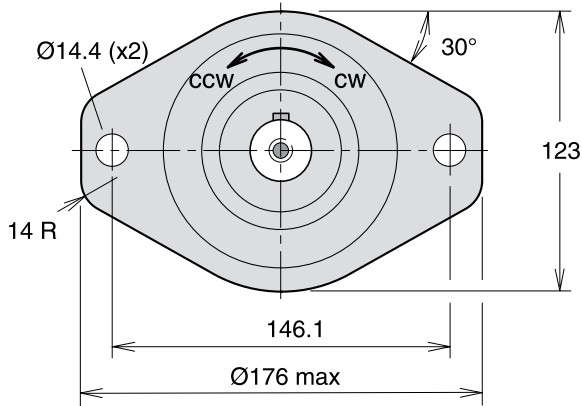

Type **S** mounting flange SAE 'B' (SAE J744c)

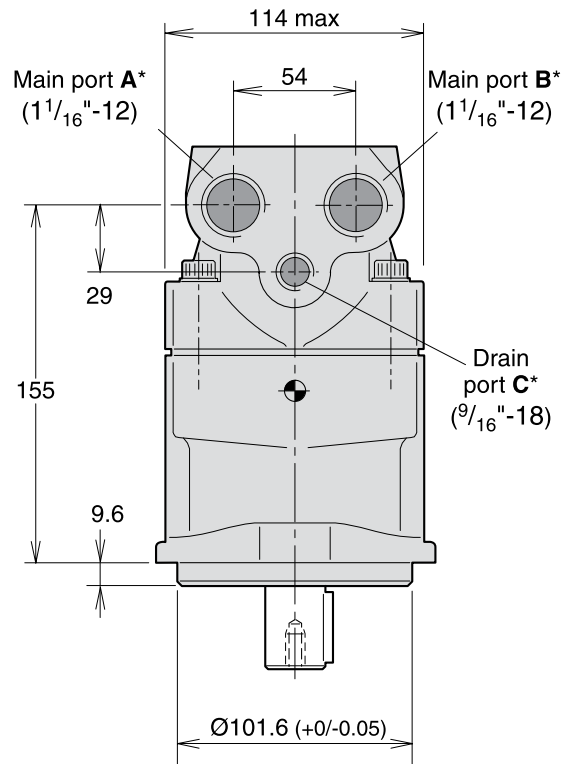
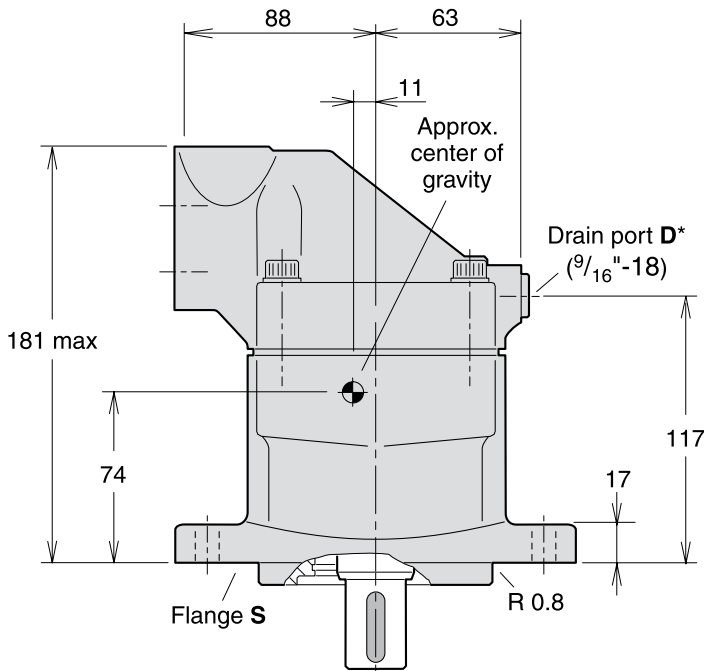

* O-ring ports according to SAE J514d

F11-019
 (SAE version)

Make up/Anti cavitation valve
 (MUVL or MUVR optional;
 clockwise rotation shown)

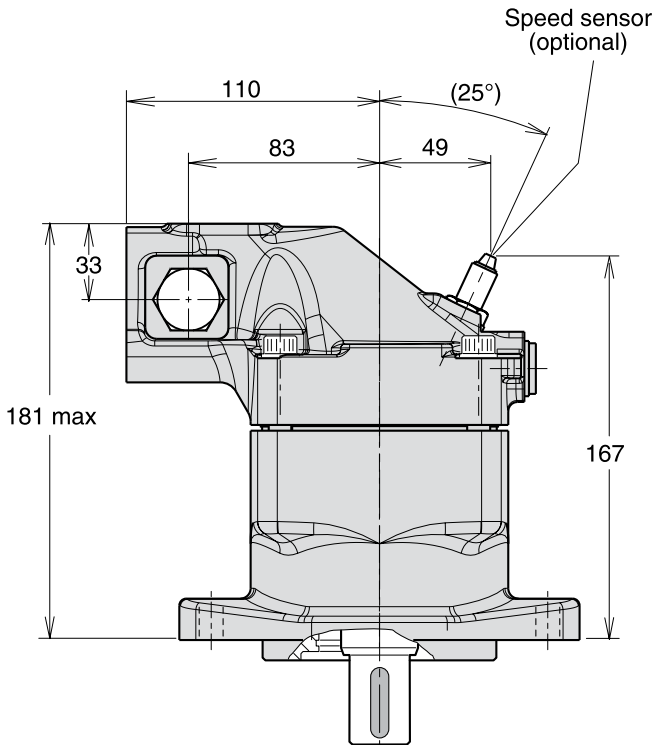
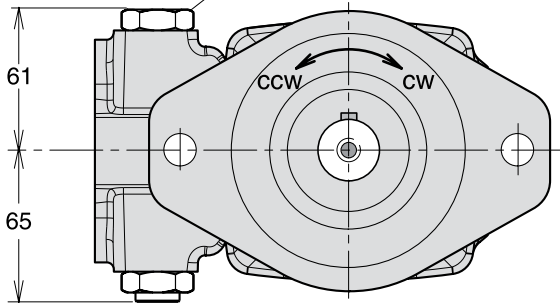

Shaft options

