

Hydraulic Pumps T7 for variable speed drives

Denison Vane Technology



ENGINEERING YOUR SUCCESS.

AVAILABILITY

Worldwide distribution
sales force and service

FLEXIBILITY

Solutions for global
and regional challenges

SUSTAINABILITY

Protecting people
and environment

PROFITABILITY

Serving for greater value to you
and your business

RELIABILITY

Maximizing uptime
and optimizing performance



ENGINEERING YOUR SUCCESS.





Contents

T7, Denison Vane Pumps

General Information	Introduction and product key features _____	3
Main Technical Data	Main table for single pumps _____	4
	Main table for double pumps _____	5
	Inlet pressure range _____	6
	Outlet pressure range _____	7
	Pump operating range _____	8 - 9
	Control modes _____	10
	Hydraulic fluids and seals _____	10
Ordering Code and Dimensions	Pumps	
	T7A _____	11
	T7AS _____	12
	T7ASW _____	13
	T7B _____	14
	T7BS _____	15
	T7D _____	16
	T7DS _____	17
	T7BB _____	18
	T7BBS _____	19
	T7DB _____	20
	T7DBS _____	21
	T7DD _____	22
	T7DDS _____	23
	Porting diagrams for double pumps _____	24
Technical Data	Performance curves, maximum torque and loads on shafts	
	T7A - T7AS _____	25
	T7ASW _____	26
	T7B - T7BS _____	27
	T7D - T7DS _____	28
	T7BB - T7BBS _____	29
	T7DB - T7DBS _____	30
	T7DD - T7DDS _____	31
Pump Selection	Pump selection example _____	32 - 33
	Time restriction principle _____	34
	Time restriction tables _____	35 - 38
Circuit Design	Pressure holding _____	39
	Decompression _____	40
	Dynamic characteristics _____	40
	Pump installation _____	41
	Start-up instructions _____	42
	Maintenance _____	42
	Warning _____	43

T7 pumps for variable speed drives

Introduction

Parker Hannifin is proud to introduce in this catalogue its selection of hydraulic vane pumps especially dedicated to variable speed drive applications. The unique technology of these hydraulic pumps is allowing a wide range of operating speeds, to take the maximum benefits of modern power transmissions. When driven with asynchronous or synchronous electric motors and piloted by frequency controllers, they operate in the most efficient and reliable ways, allowing maximum energy savings.

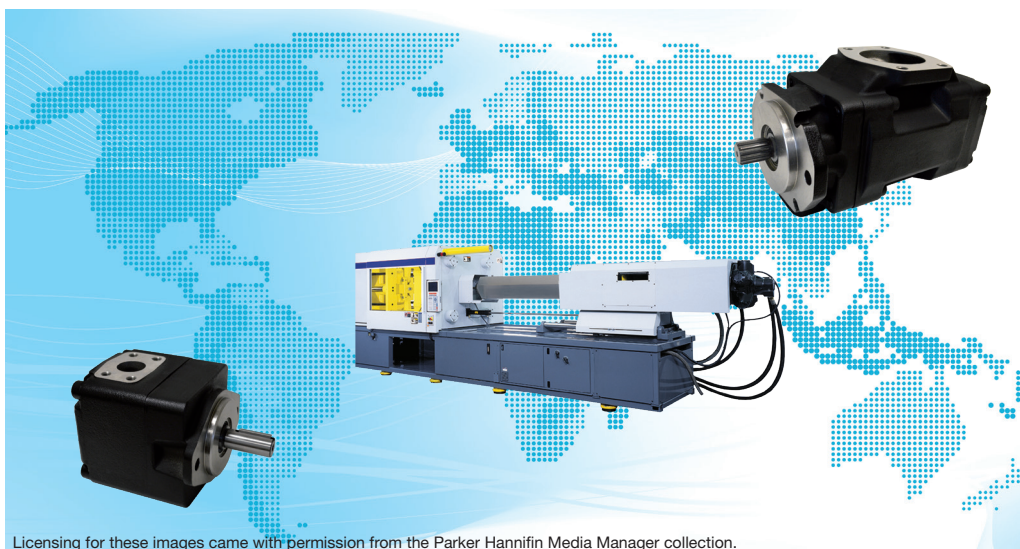

Licensing for these images came with permission from the Parker Hannifin Media Manager collection.

Main benefits of variable speed drives

Energy savings

Up to 70% less electric Energy for the E Motor and less or no cooling for the hydraulic equipment.

Lower noise emissions.

Lower total cost of the hydraulic system

Smaller pump, less valves, less or no cooling, smaller fluid tank, increased lifetime for the components.

Product key features

Reliable performance

These T7 hydraulic pumps have been designed especially for variable speed drives and are offering a wide speed range. Like all our T7 Series vane pumps, the performances do remain very stable over time, making these pumps an ideal solution for modern electro-hydraulically operated machines.

Long lifetime

The fully pressure balanced concept increases the pump lifetime over its full operating range while double lip vanes reduce the sensitivity to fluid pollution.

Low noise

The Denison Vane Technology allows very low noise levels over the entire operating range and during the whole life of the pump.

Versatility and compactness

With several displacements for the same installation size, the T7 are a very powerful and compact pumps. The various pumping units (cartridge kits) can also be combined with other pumping unit sizes in multiple pumps. This creates a wide range of multi flow pumps, very much adapted to the high power needs.

Main Technical Data

T7, Denison Vane Pumps

Single Pumps		Theoretical Displacement Vi cm ³ /rev.	Maximum Speed		Maximum Pressure											
Type	Ring size		HF-0, HF-1 HF-2	HF-4, HF-5 ³⁾	HF-0, HF-2		HF-1, HF-4, HF-5									
			rpm	rpm	Int. bar	Cont. bar	Int. bar	Cont. bar								
T7A T7AS	E06	5,8	3600	1800	290	260	240	210								
	E10	9,8														
	E11	11,0														
	E13	12,8														
	E17	17,2														
	E20	19,8														
	E22	22,5	3000		275	240										
E25	24,9															
T7ASW	E22	22,0	3600	1800	300	275	240	210								
	E26	26,0														
	E28	28,0	3400													
	E30	30,0	3100													
	E32	31,8	3000		280	240										
	E34	34,0	2800													
	E36	36,0	2600													
	E40	40,0	2300													
T7B T7BS	E03	9,8	3600	1800	320 ¹⁾	290	240	210								
	E04	12,8														
	E05	15,9														
	E06	19,8														
	E07	22,5														
	E08	24,9														
	E09	28,0	3400		300	275										
	E10	31,8														
	E11	35,0	3000						280	240						
	E12	41,0														
	E14	45,0	3000 ²⁾													
	E15	50,0														
T7D T7DS	E14	44,0	3000	1800	300	250	240	210								
	E17	55,0														
	E20	66,0														
	E22	70,3														
	E24	81,1														
	E28	90,0														
	E31	99,2	2800		280											
	E35	113,4														
	E38	120,6														
	E42	137,5							2500	260	230					

¹⁾ Please consult Parker for application over 300 bar.

²⁾ 2700 for pump with M0 ports.

³⁾ with 1,2 m/s fluid velocity

HF-0, HF-2 = Antiwear Petroleum Base

HF-1 = Non Antiwear Petroleum Base

HF-4 = Water Glycols Solutions

HF-5 = Synthetic Fluids

Note : For further information or if the performance characteristics outlined in the table do not meet your particular requirements, please consult your local Parker office.

Double Pumps		Theoretical Displacement Vi cm ³ /rev.	Maximum Speed		Maximum Pressure			
Type	Ring size		HF-0, HF-1 HF-2	HF-4, HF-5 ³⁾	HF-0, HF-2		HF-1, HF-4, HF-5	
			rpm	rpm	Int. bar	Cont. bar	Int. bar	Cont. bar
T7BB T7BBS T7DB T7DBS	E03	9,8	3000	1800	300	275	240	210
	E04	12,8						
	E05	15,9						
	E06	19,8						
	E07	22,5						
	E08	24,9						
	E09	28,0						
	E10	31,8						
	E11	35,0						
	E12	41,0						
	E14	45,0						
	E15	50,0	2700		280	240		
T7DB T7DBS	E14	44,0	3000	1800	300	250	240	210
	E17	55,0						
	E20	66,0						
	E22	70,3						
	E24	81,1						
	E28	90,0						
	E31	99,2						
		E35	113,4	2800		280		
		E38	120,6					
		E42	137,5	2500		260	230	
T7DD T7DDS	E14	44,0	3000	1800	300	250	240	210
	E17	55,0						
	E20	66,0						
	E22	70,3						
	E24	81,1						
	E28	90,0						
	E31	99,2						
		E35	113,4	2800		280		
		E38	120,6					
		E42	137,5	2500		260	230	

³⁾ with 1,2 m/s fluid velocity

HF-0, HF-2 = Antiwear Petroleum Base

HF-1 = Non Antiwear Petroleum Base

HF-4 = Water Glycols Solutions

HF-5 = Synthetic Fluids

Note : For further information or if the performance characteristics outlined in the table do not meet your particular requirements, please consult your local Parker office.

Main Technical Data

T7, Denison Vane Pumps

Inlet pressure range

- **Minimum inlet pressure** : Read the minimum inlet pressure requirement in the below table, depending on the pump type, ring size and its maximum operating speed. Never go under 0,8 bar Absolute (11.6 psi Absolute).

Cartridge		Speed rpm													
Size	Ring	1200	1500	1800	2100	2200	2300	2500	2600	2700	2800	3000	3100	3400	3600
A AS	E06	0,80	0,80	0,80	0,80	0,80	0,80	0,80	0,80	0,80	0,80	0,80	0,80	0,80	0,80
	E10														
	E11														
	E13														
	E17														
	E20														
	E22														
E25															
ASW	E22	0,80	0,80	0,80	0,80	0,80	0,80	0,80	0,80	0,80	0,80	0,80	0,80	0,80	0,80
	E26														
	E28														
	E30														
	E32														
	E34														
	E36														
E40															
B BS	E03	0,80	0,80	0,80	0,80	0,80	0,80	0,80	0,80	0,80	0,80	0,80	0,80	0,80	0,80
	E04														
	E05														
	E06														
	E07														
	E08														
	E09														
	E10														
	E11														
	E12														
	E14														
E15															
D DS	E14	0,80	0,80	0,80	0,80	0,80	0,80	0,80	0,80	0,80	0,80	0,80	0,80	0,80	0,80
	E17														
	E20														
	E22														
	E24														
	E28														
	E31														
	E35														
	E38														
	E42														

Inlet pressure is measured at inlet flange with petroleum base fluids at viscosity between 10 and 65 cSt. The difference between inlet pressure at the pump flange and atmospheric pressure must not exceed 0,2 bar to prevent aeration.

Multiply absolute pressure by 1,25 for HF-4 fluid and by 1,35 for HF-5 fluid.

For double pumps, take the value of the cartridge requiring the highest absolute pressure.

- **Maximum inlet pressure** : Read the information on the product key sheet page. Standard shaft seals are limited to 0,7 bar (10 psig) but some allow 7 bar (100 psig).

Outlet pressure range

- **Minimum outlet pressure** : It is recommended to always keep at least 1,5 bar (22 psi) differential between inlet and outlet.
- **Maximum outlet pressure** : Please read the charts in this catalogue for the Max continuous and the Max intermittent pressure ratings. Depending on the average pressure in cycle, either the continuous or the intermittent will be the limit.
- **Average pressure in cycle** : These Pumps may be operated intermittently at pressures higher than the recommended continuous rating when the time weighted average of pressure is less than or equal to the continuous duty pressure rating. This intermittent pressure rating calculation is only valid when the other parameters : speed, fluid, viscosity and contamination level are respected.

For total cycle time longer than 15 minutes, please consult your Parker representative.

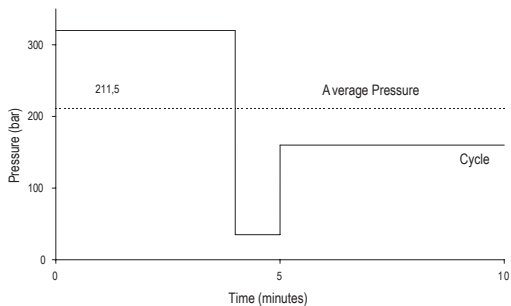

Example : T7B - E10

Duty cycle 4 min. at 320 bar

1 min. at 35 bar

5 min. at 160 bar

$$\frac{(4 \times 320) + (1 \times 35) + (5 \times 160)}{10} = 211,5 \text{ bar}$$

211,5 bar is lower than 290 bar allowed as continuous pressure for T7B - E10 with HF-0 fluid.

How to read a pump operating range chart

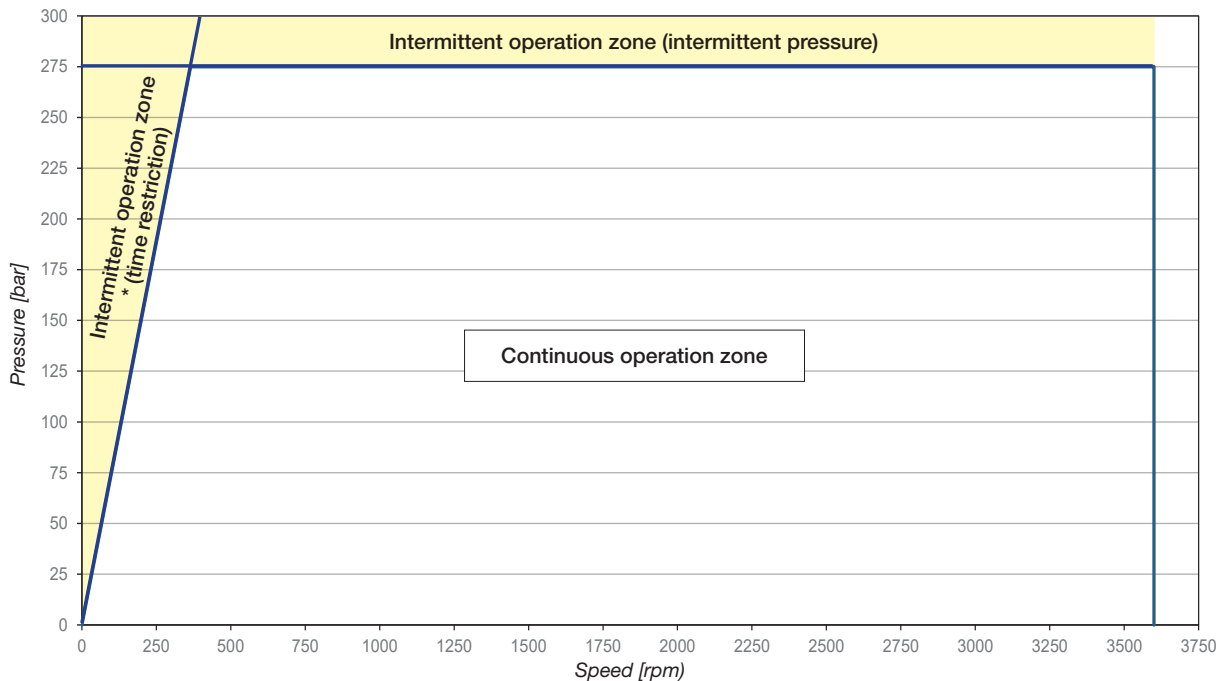

For double pumps, check the operating range of each pumping unit. Restrict the max. speed and max. pressure to the values indicated in the table page 5.

* The pump rotation speed must allow a pressure build up : $Q > Q_{leak@p}$

T7A - T7AS Operating Range

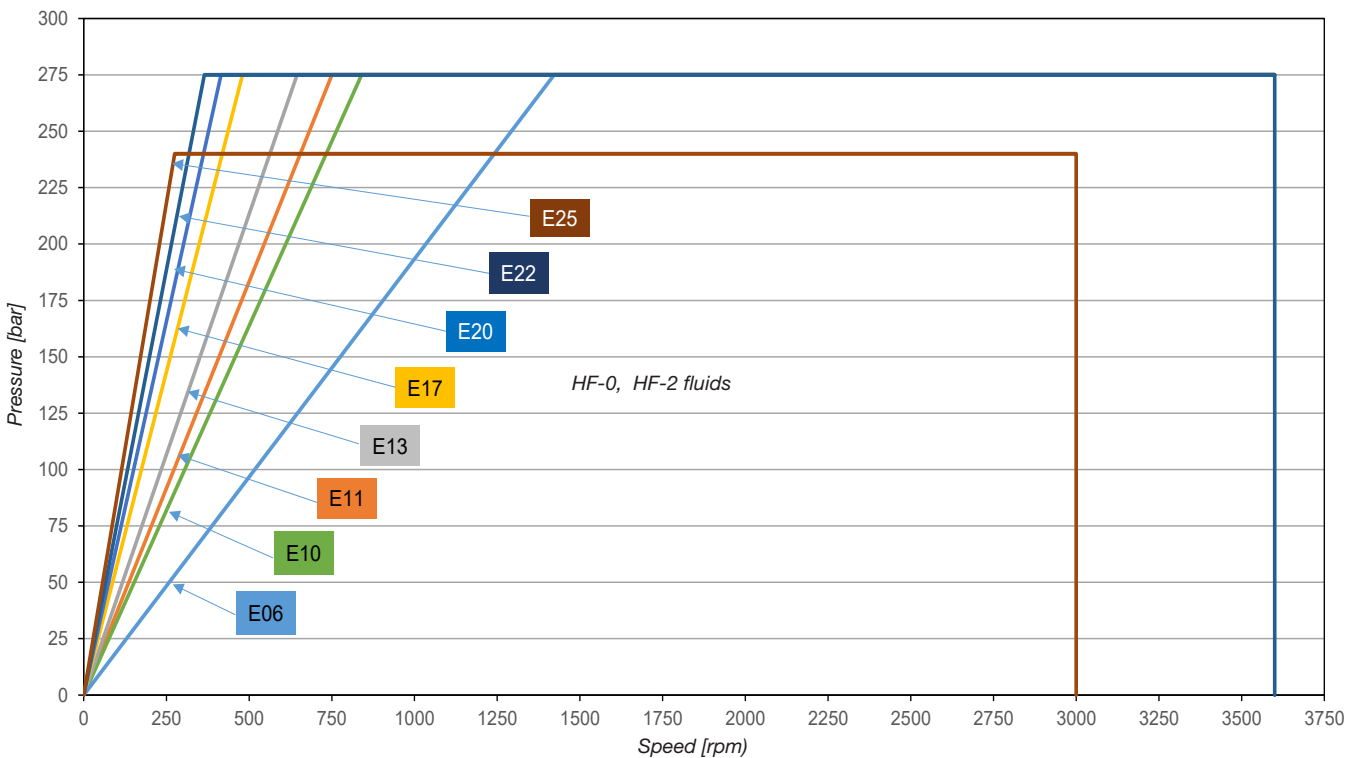

T7ASW Operating Range

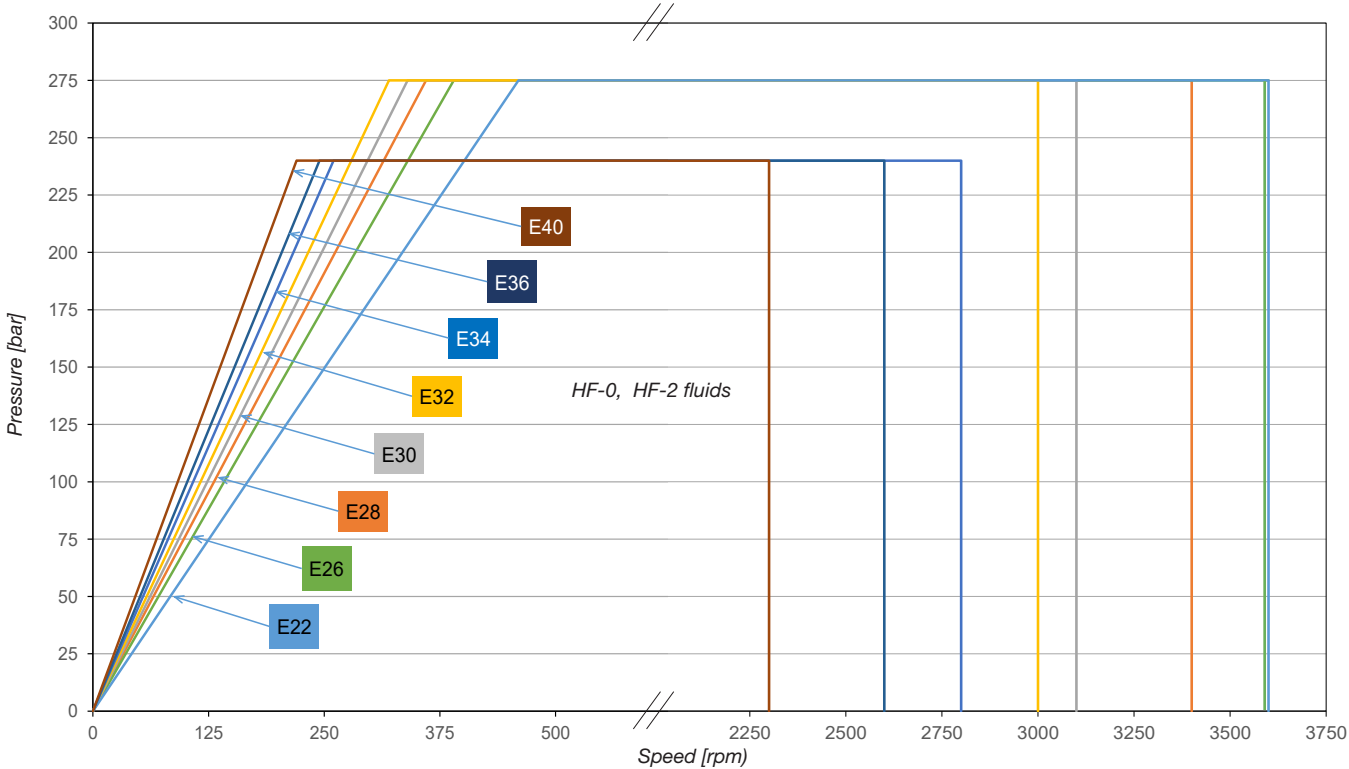

T7B - T7BS Operating Range

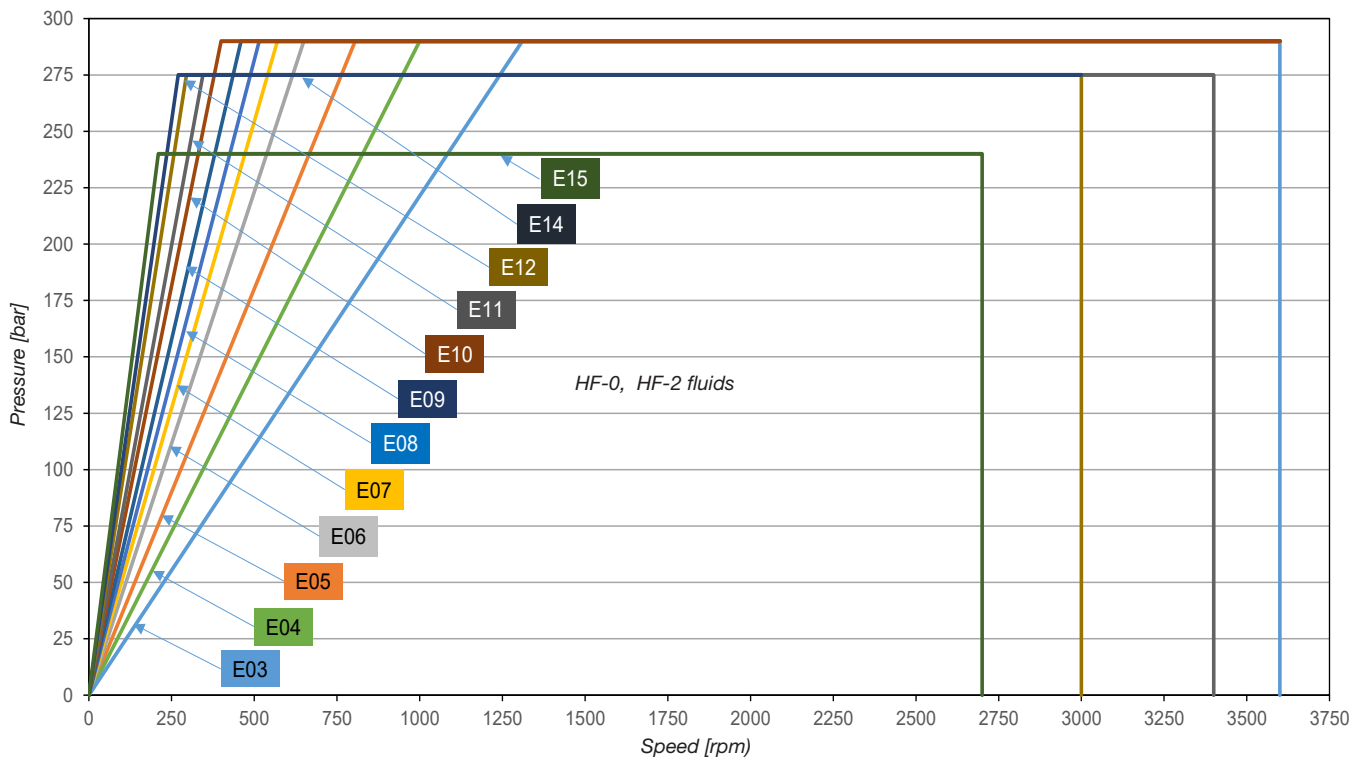

T7D - T7DS Operating Range

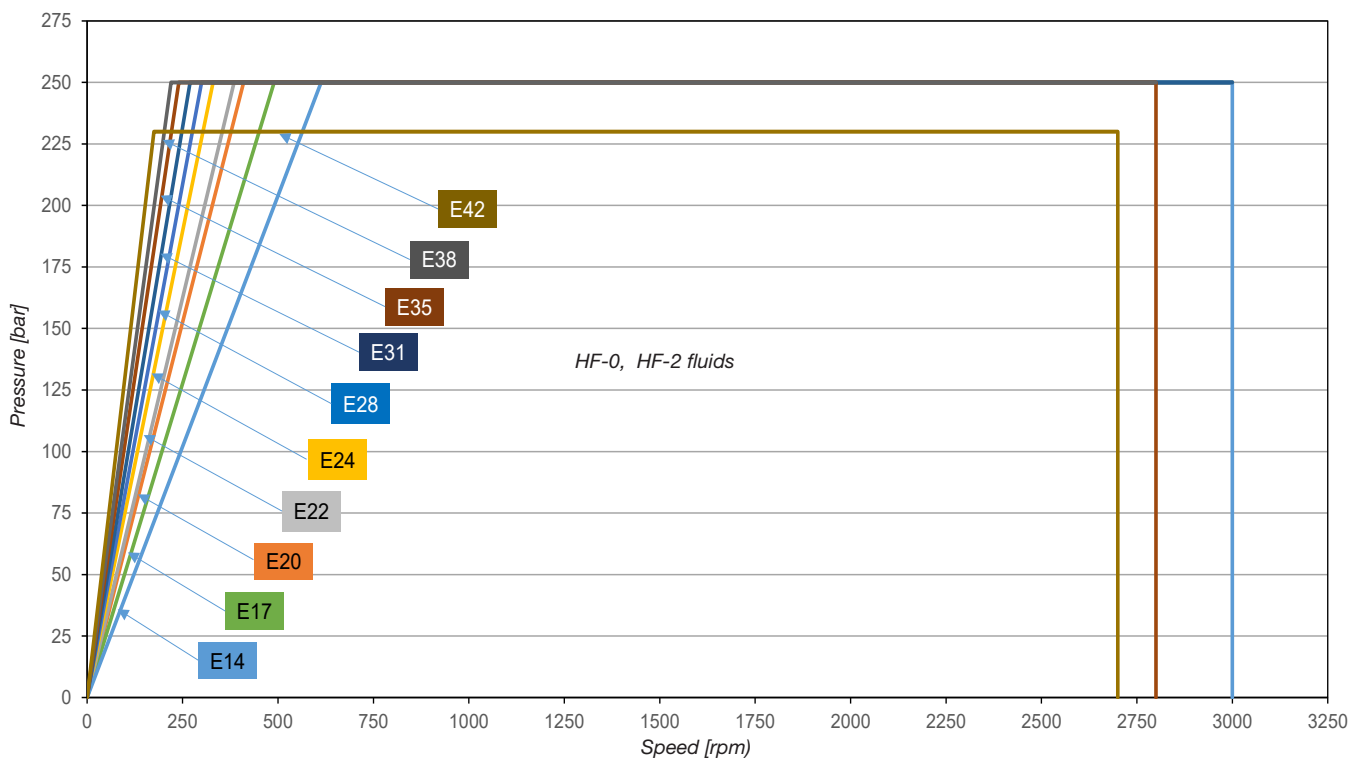

Control modes

Our fixed displacement pumps, when driven at variable speeds, may operate in hydraulic open loop circuits with various control modes.

Flow control mode

The pump flow is varied according to the speed command signal of the drive unit. The necessary pressure limitation is achieved by a pressure relief valve in a classic way.

Pressure / Flow control mode

The pump flow is varied according to the speed command signal of the drive unit which also offers the ability to switch in pressure control mode. This mode requires fast pressure sensors, a servomotor with high dynamics, as well as a fast drive unit. The necessary pressure limitation is achieved by the pump and motor unit that only deliver enough fluid to limit the pressure to the set value. A pressure relief valve remains necessary, but as a safety device only. This control mode may require a specific circuit design.

Regenerative mode

With a suitable hydraulic circuitry and when driven in its opposite rotation way, the pump may be used as a hydraulic motor, offering an energy recovery functionality. However, for this hydraulic motor function being limited, please consult your local Parker office.

Hydraulic fluids

Recommended fluids

Petroleum base anti-wear, anti-rust and anti-oxidation fluids (covered by Parker Denison HF-0 and HF-2 specifications). Maximum catalogue ratings and performance data are based on operation with these fluids.

Acceptable alternate fluids

The use of fluids other than petroleum based antiwear R & O fluids requires the maximum ratings of the pumps to be reduced, when the minimum inlet pressures must be increased.

Fluids viscosity

The minimum Viscosity Index is 90. The kinematic viscosity range is as below. Over or under these values, please contact Parker.

Max. (cold start, low speed & pressure) ___ 2000 cSt	Min. (full speed & pressure for HF-1, HF-4 & HF-5 fluids) _____ 18 cSt
Max. (full speed & pressure) _____ 108 cSt	Min. (full speed & pressure for HF-0 & HF-2 fluids) _____ 10 cSt
Optimum (max. lifetime) _____ 30 cSt	

Fluids temperatures

The usual limiting factor of temperature (low or high) comes from the obtained viscosity. The seals are sometimes the limit.

Maximum fluid temperature (also depends on min. viscosity)	Minimum fluid temperature (also depends on max. viscosity).
° C ° F	° C ° F
HF-0, HF-1, HF-2 _____ + 100 (+ 212)	HF-0, HF-1, HF-2, HF-5 _____ - 18 (- 0.4)
HF-4 _____ + 50 (+ 122)	HF-4 _____ + 10 (+ 50)
HF-5 _____ + 70 (+ 158)	

Filtration requirement

The fluid must be cleaned before and during operation to maintain a contamination level of ISO 19 / 17 / 14 or NAS 1638 class 8 or better. No inlet strainer or inlet filter is allowed on the fixed displacement pumps for variable speed drives.

Water contamination in the fluid

The maximum acceptable content of water shall be limited to 0,10 % for mineral base fluids, and 0,05 % for synthetic fluids, crankcase oils, and biodegradable fluids. The eventual excess of water must be drained off the circuit.

Types of seals

NBR seals S1 : Use this seal type for standard applications : with mineral oil and fluid temperature less than + 90° C (+ 194° F).

S1 seals temperature range : - 40°C to + 107° C (- 40° F to + 225° F).

EPDM seals S4 : Use this seal type when recommended by the fluid manufacturer.

S4 seals temperature range : - 54° C to + 121° C (- 65° F to + 250° F).

FPM seals S5 : Use this seal type with some fire resistant fluids and/or fluid temperature higher than + 90° C (+194° F).

S5 seal temperature range : - 29° C to + 204°C (- 20° F to + 400°F).

Model No.

T7A - E17 - 2 R 00 - B 1 - 05 - M

T7A series - 80-A2-HW
ISO 2 bolts 3019-2 mounting flange

Displacement
Volumetric displacement (cm³/rev.)

- E06 = 5,8
- E10 = 9,8
- E11 = 11,0
- E13 = 12,8
- E17 = 17,2
- E20 = 19,8
- E22 = 22,5
- E25 = 24,9

Type of shaft
2 = keyed ISO R775

Direction of rotation (shaft end view)
R = Clockwise
L = Counter-clockwise

Modifications
Ex : NOP = Not painted

Ports
05 = BSPP threads
S = 1.1/4" BSPP
P = 3/4" BSPP

Seal class
1 = S1 BUNA N - 0,7 bar max. (for mineral oil)
5 = S5 VITON® - 7 bar max. (for mineral oil and fire resistant fluids)

Design letter

Porting combination
00 = standard

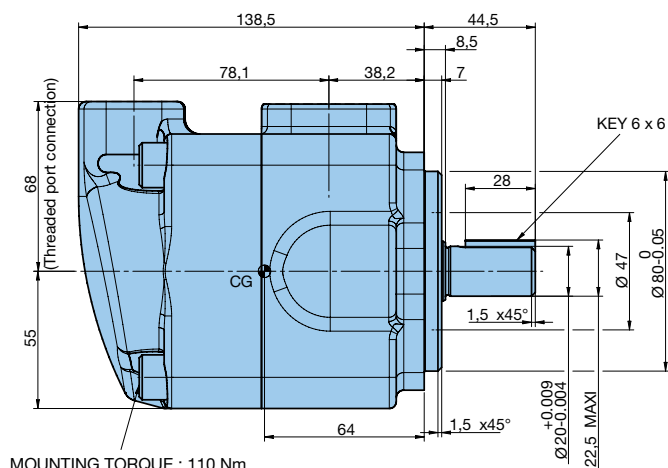
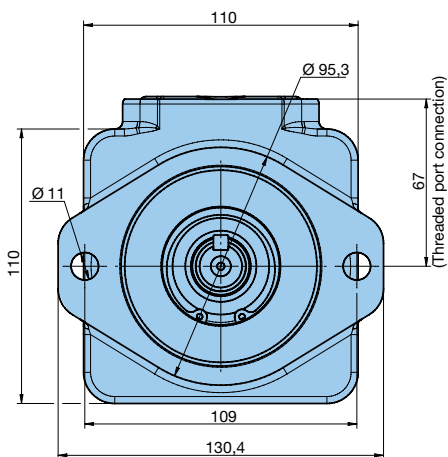
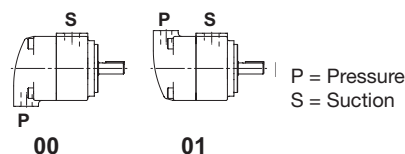

Shaft Code 2
KEYED (ISO R775)

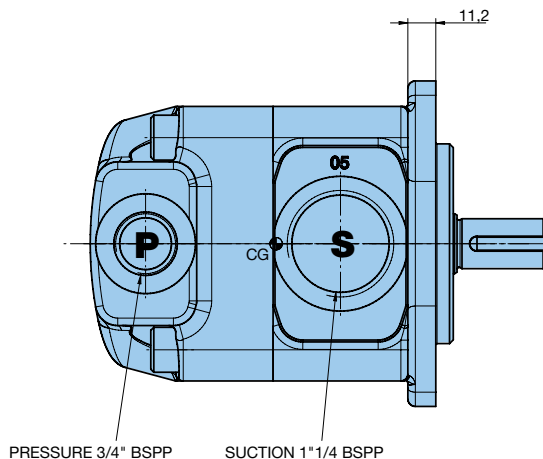

Model No. T7AS - E17 - 1 R 00 - B 1 - 06 - M

T7AS series - SAE A 2 bolts
J744 mounting flange

Displacement
Volumetric displacement (cm³/rev.)
E06 = 5,8
E10 = 9,8
E11 = 11,0
E13 = 12,8
E17 = 17,2
E20 = 19,8
E22 = 22,5
E25 = 24,9

Type of shaft
1 = keyed (non SAE) Ø 19,05
3 = splined 16/32 (SAE B) 13 teeth
4 = splined 16/32 (SAE A) 9 teeth

Modifications
Ex : NOP = Not painted

Ports
M6 = 4 bolts SAE flanges J518 with Metric thread
06 = 4 bolts SAE flanges J518 with UNC thread
S = 1.1/4"
P = 3/4"

Seal class
1 = S1 BUNA N - 0,7 bar max. (for mineral oil)
5 = S5 VITON® - 7 bar max. (for mineral oil and fire resistant fluids)

Design letter

Porting combination
00 = standard

Direction of rotation (shaft end view)
R = Clockwise
L = Counter-clockwise

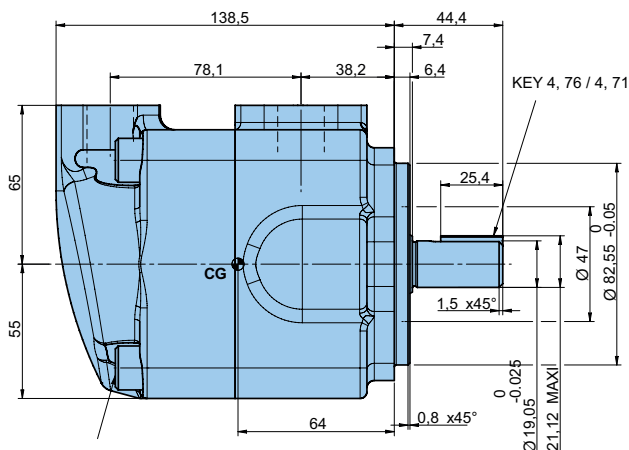
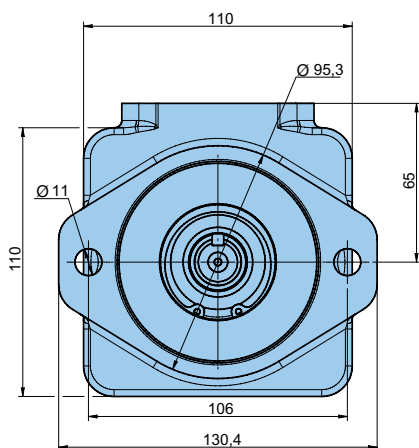
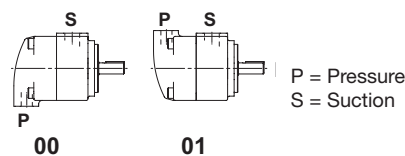

MOUNTING TORQUE : 110 Nm

Shaft Code 1
KEYED (NON SAE)

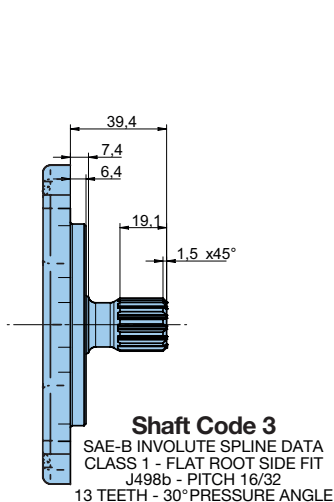

7/16"-14 UNC-2B x 19 DEEP - 4 HOLES - UNC VERSION
M10 x 19 DEEP - 4 HOLES - METRIC VERSION

3/8"-16 UNC-2B x 17 DEEP - 4 HOLES - UNC VERSION
M10 x 17 DEEP - 4 HOLES - METRIC VERSION

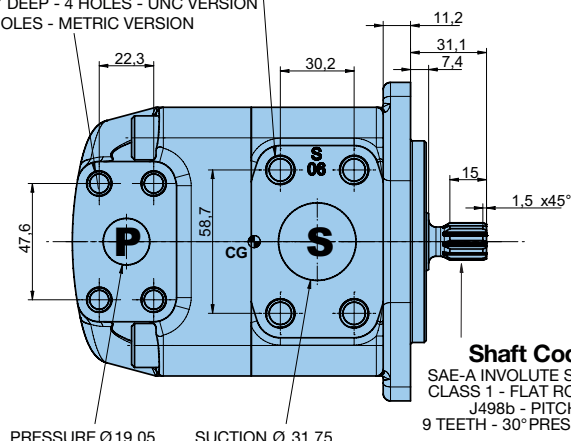

Model No. T7ASW - E32 - 1 R 00 - B 1 - 06 - M

T7ASW series - SAE A 2 bolts
J744 mounting flange

Displacement
Volumetric displacement (cm³/rev.)
E22 = 22,0
E26 = 26,0
E28 = 28,0
E30 = 30,0
E32 = 31,8
E34 = 34,0
E36 = 36,0
E40 = 40,0

Type of shaft
1 = keyed (non SAE) Ø 19,05
3 = splined 16/32 (SAE B) 13 teeth
4 = splined 16/32 (SAE A) 9 teeth

Modifications
Ex : NOP = Not painted

Ports
M6 = 4 bolts SAE flanges J518 with Metric threads
06 = 4 bolts SAE flanges J518 with UNC threads
S = 1.1/4"
P = 3/4"

Seal class
1 = S1 BUNA N - 0,7 bar max. (for mineral oil)
5 = S5 VITON® - 7 bar max. (for mineral oil and fire resistant fluids)

Design letter

Porting combination
00 = standard

Direction of rotation (shaft end view)
R = Clockwise
L = Counter-clockwise

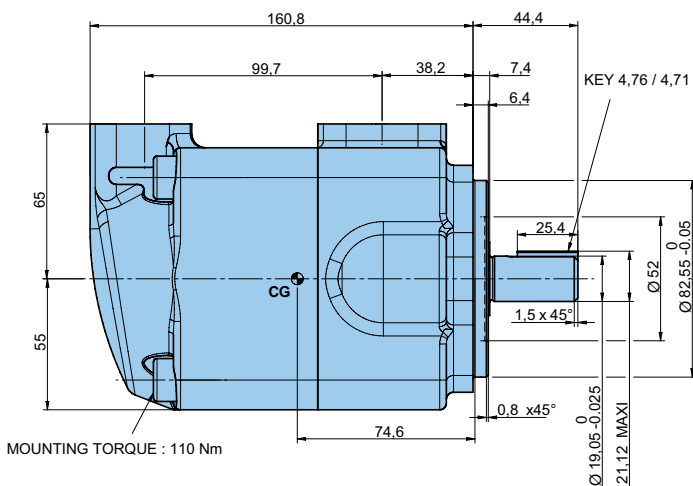
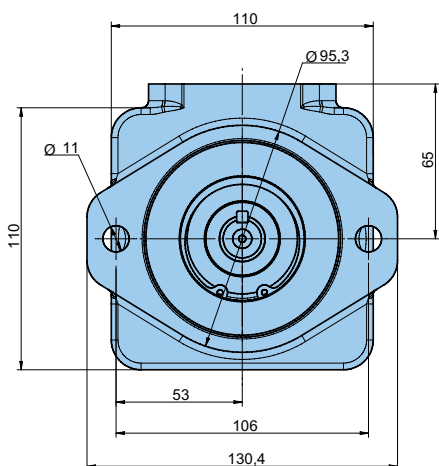
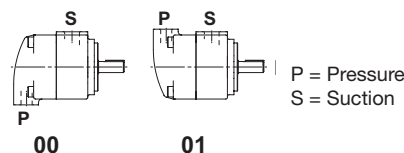

Shaft code 1
(KEYED NO SAE)

7/16"-14 UNC-2B x 19 DEEP - 4 HOLES - UNC VERSION
M10 x 19 DEEP - 4 HOLES - METRIC VERSION

3/8"-16 UNC-2B x 17 DEEP - 4 HOLES - UNC VERSION
M10 x 17 DEEP - 4 HOLES - METRIC VERSION

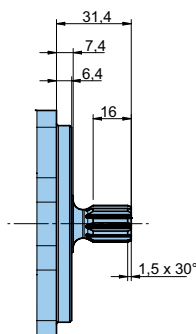

Shaft Code 4
SAE-A INVOLUTE SPLINE DATA
CLASS 1 - FLAT ROOT SIDE FIT
J498b - PITCH 16/32
9 TEETH - 30° PRESSURE ANGLE

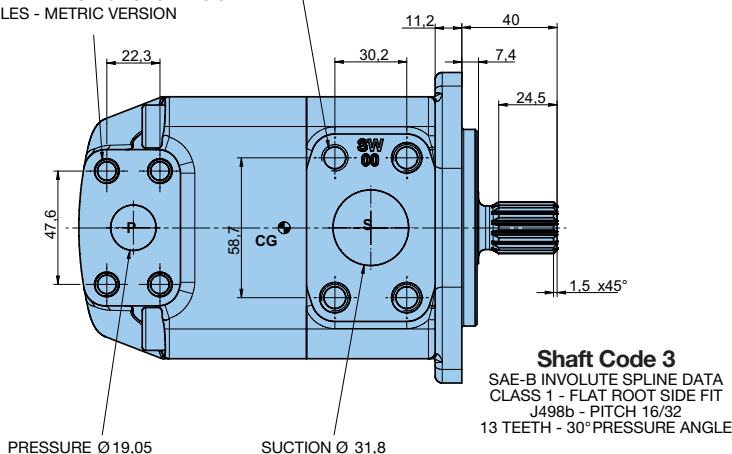

Shaft Code 3
SAE-B INVOLUTE SPLINE DATA
CLASS 1 - FLAT ROOT SIDE FIT
J498b - PITCH 16/32
13 TEETH - 30° PRESSURE ANGLE

T7B - Ordering Code & Dimensions

Hydraulic Pumps for variable speed drives T7, Denison Vane Pumps

Model No.

T7B - E10 - 2 R 00 - A 1 - M0 - M

T7B series - 100 A2 HW
ISO 2 bolts 3019-2 mounting flange

Displacement
Volumetric displacement (cm³rev.)
E03 = 9,8 E09 = 28,0
E04 = 12,8 E10 = 31,8
E05 = 15,9 E11 = 35,0
E06 = 19,8 E12 = 41,0
E07 = 22,5 E14 = 45,0
E08 = 24,9 E15 = 50,0

Type of shaft
2 = keyed (ISO R775)

Direction of rotation (shaft end view)
R = Clockwise
L = Counter-clockwise

Modifications
Ex : NOP = Not painted

Ports
MW =
S = Specific flange pattern
P = 1" - SAE flange J518 with Metric threads
M0 = 4 bolts SAE flanges J518 with Metric threads
S = 1.1/2"
P = 1"

Seal class
1 = S1 BUNA N - 0,7 bar max. (for mineral oil)
4 = S4 EPDM - 0,7 bar max. (for fire resistant fluids)
5 = S5 VITON® - 0,7 bar max. (for mineral oil and fire resistant fluids)

Design letter

Porting combination
00 = standard

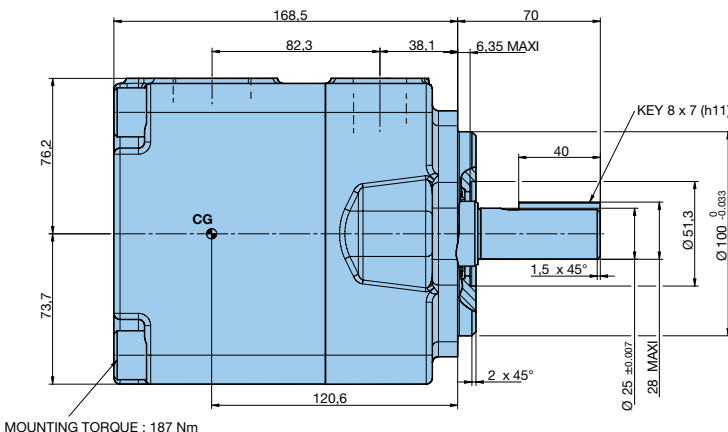
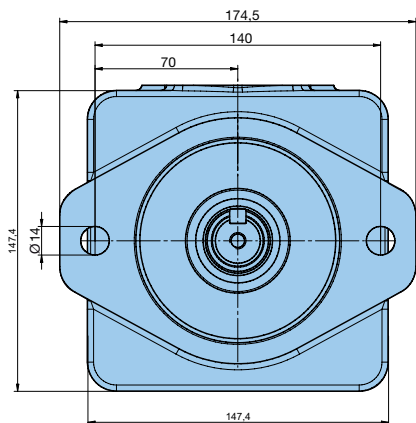
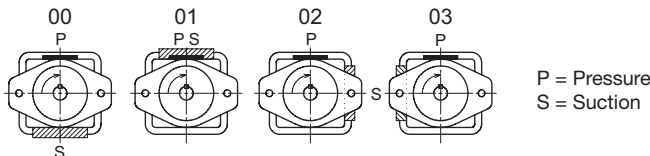

2.1/2" inlet flange
034-68306-0
+ O ring
671-00137-0

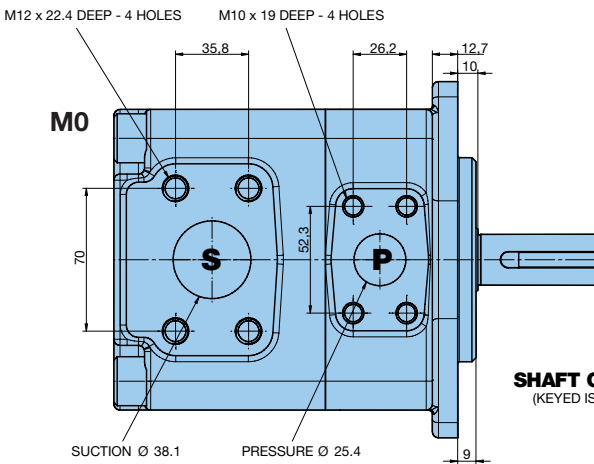
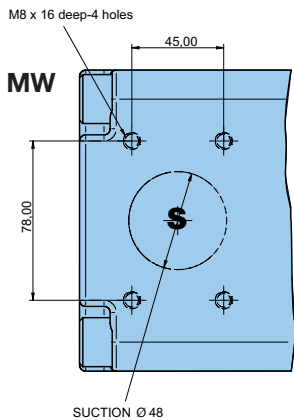
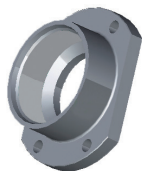

Model No. T7BS - E10 - 1 R 00 - A 1 - M0 - M

T7BS series - SAE B 2 bolts
J744 mounting flange

Displacement
Volumetric displacement (cm³rev.)

E03 = 9,8	E09 = 28,0
E04 = 12,8	E10 = 31,8
E05 = 15,9	E11 = 35,0
E06 = 19,8	E12 = 41,0
E07 = 22,5	E14 = 45,0
E08 = 24,9	E15 = 50,0

Type of shaft

- 1 = keyed (SAE B)
- 3 = splined 16/32 (SAE B) 13 teeth
- 4 = splined 16/32 (SAE BB) 15 teeth

Direction of rotation (shaft end view)

- R = Clockwise
- L = Counter-clockwise

Modifications
Ex : NOP = Not painted

Ports
MW =
S = Specific flange pattern
P = 1" - SAE flange J518 with Metric threads
M0 = 4 bolts SAE flange J518 with Metric threads
00 = 4 bolts SAE flange J518 with UNC threads
S = 1.1/2"
P = 1"

Seal class

- 1 = S1 BUNA N - 0,7 bar max. (for mineral oil)
- 4 = S4 EPDM - 0,7 bar max. (for fire resistant fluids)
- 5 = S5 VITON® - 0,7 bar max. (for mineral oil and fire resistant fluids)

Design letter

Porting combination
00 = standard

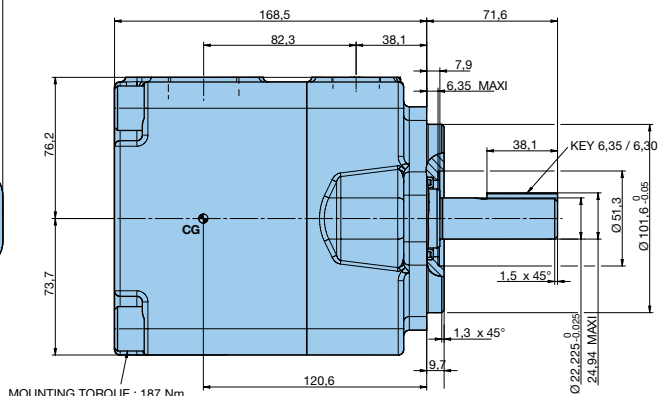
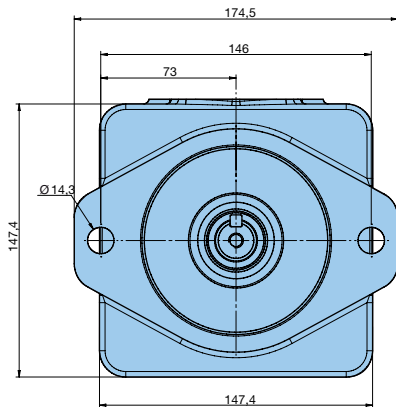
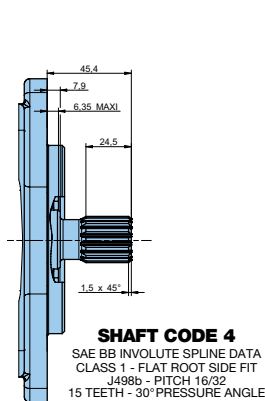
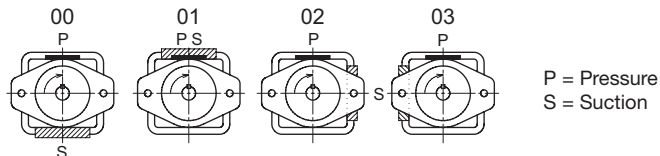

MOUNTING TORQUE : 187 Nm

SHAFT CODE 1
(KEYED SAE B)

2.1/2" inlet flange
034-68306-0
+ O ring
671-00137-0

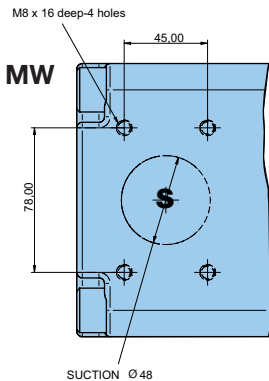
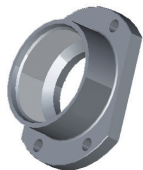

1/2"-13 UNC x 22.4 DEEP - 4 HOLES
M12 x 22.4 DEEP - METRIC VERSION

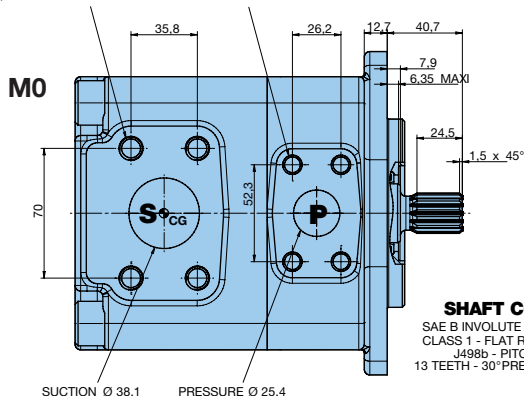

SHAFT CODE 3
SAE B INVOLUTE SPLINE DATA
CLASS 1 - FLAT ROOT SIDE FIT
J498b - PITCH 16/32
13 TEETH - 30° PRESSURE ANGLE

T7D - Ordering Code & Dimensions

Model No

T7D - E42 - 5 R 00 - A 1 - MW - $\frac{M}{M}$

T7D series - 125 A2 HW
 ISO 2 bolts 3019-2 mounting flange

Displacement
 Volumetric displacement (cm³/rev.)
 E14 = 44,0 E28 = 90,0
 E17 = 55,0 E31 = 99,2
 E20 = 66,0 E35 = 113,4
 E22 = 70,3 E38 = 120,6
 E24 = 81,1 E42 = 137,5

Type of shaft
 5 = keyed (ISO 3019-2 - G32M)

Direction of rotation (shaft end view)
 R = Clockwise
 L = Counter-clockwise

Modifications
 Ex : NOP = Not painted

Ports
 MW = 4 bolts SAE flange J518 with Metric threads
 S = 2.1/2"
 P = 1.1/4"

Seal class
 1 = S1 BUNA N - 0,7 bar max. (for mineral oil)
 4 = S4 EPDM - 7 bar max. (for fire resistant fluids)
 5 = S5 VITON® - 7 bar max. (for mineral oil and fire resistant fluids)

Design letter

Porting combination
 00 = standard

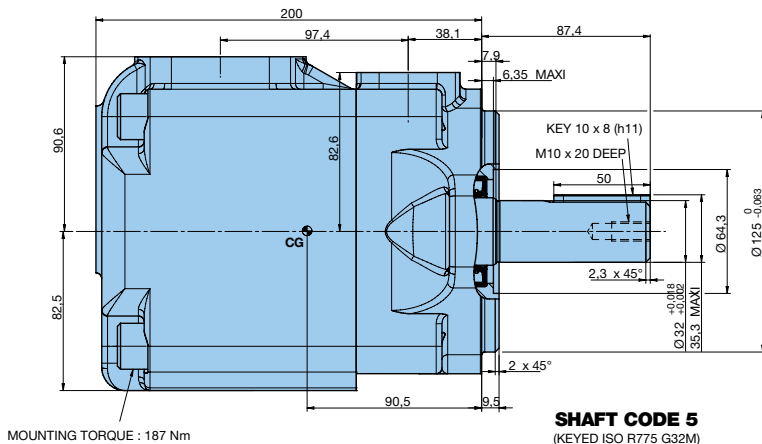
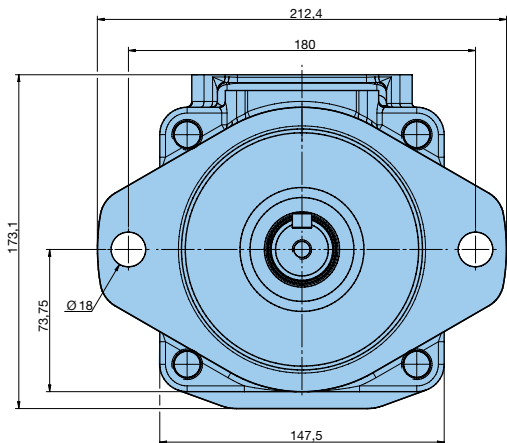
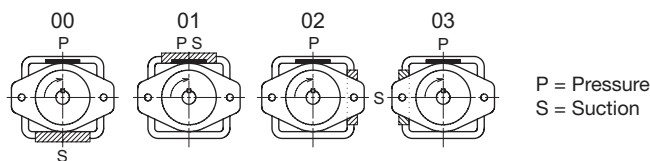

MOUNTING TORQUE : 187 Nm

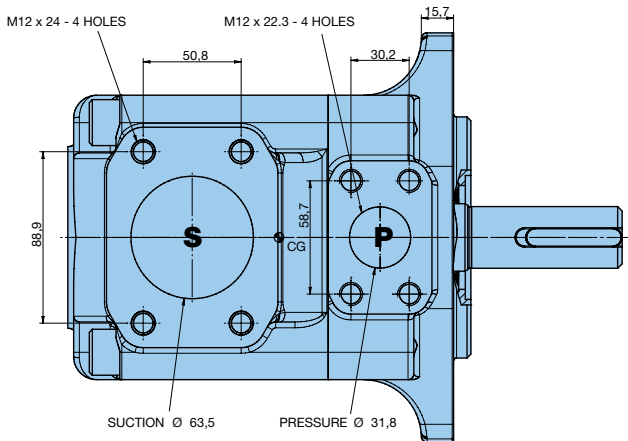

Model No

T7DS - E42 - 1 R 00 - A 1 - 0W - M

T7DS series - SAE C 2 bolts
J744 mounting flange

Displacement

Volumetric displacement (cm³/rev.)

E14 = 44,0 E28 = 90,0
E17 = 55,0 E31 = 99,2
E20 = 66,0 E35 = 113,4
E22 = 70,3 E38 = 120,6
E24 = 81,1 E42 = 137,5

Type of shaft

1 = keyed (SAE C) Ø 31,7
3 = splined 12/24 (SAE C) 14 teeth

Direction of rotation (shaft end view)

R = Clockwise
L = Counter-clockwise

Modifications

Ex : NOP = Not painted

Ports

MW = 4 bolts SAE flange J518 with Metric threads
0W = 4 bolts SAE flange J518 with UNC threads
S = 2.1/2"
P = 1.1/4"

Seal class

1 = S1 BUNA N - 0,7 bar max. (for mineral oil)
4 = S4 EPDM - 7 bar max. (for fire resistant fluids)
5 = S5 VITON® - 7 bar max. (for mineral oil and fire resistant fluids)

Design letter

Porting combination

00 = standard

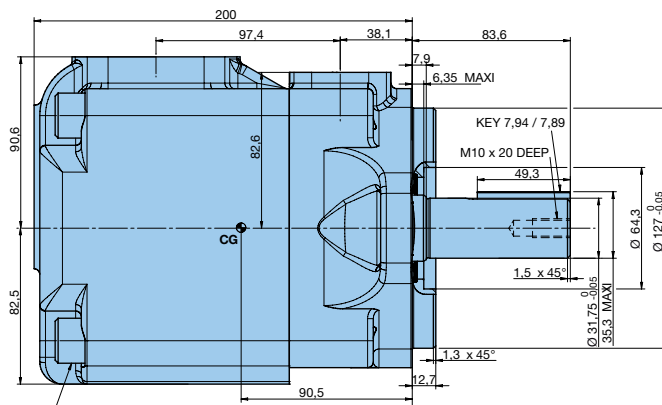
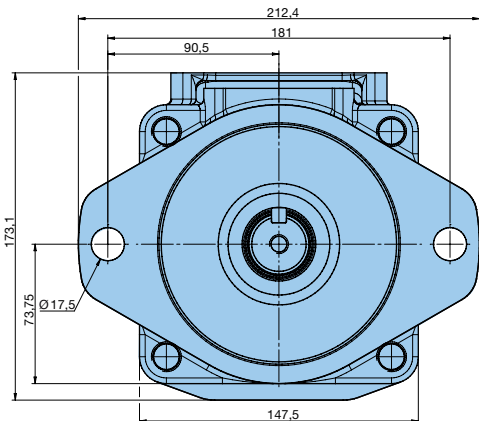
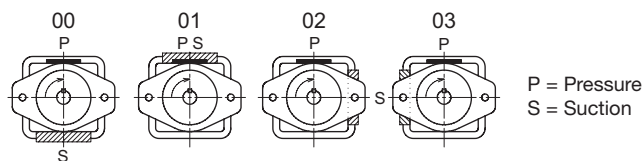

MOUNTING TORQUE : 187 Nm

SHAFT CODE 1
(KEYED SAE C)

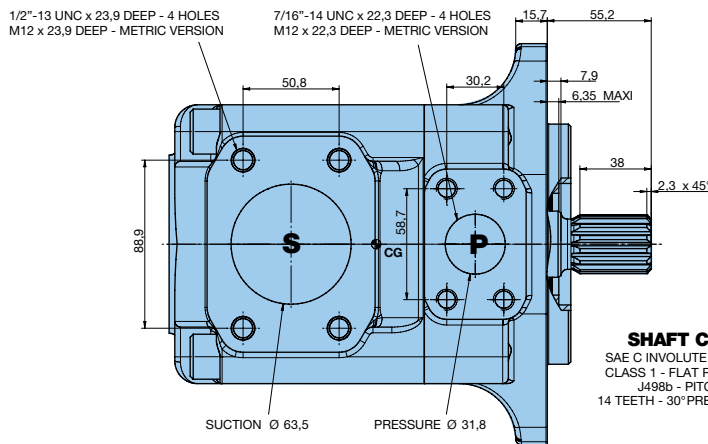

SHAFT CODE 3
SAE C INVOLUTE SPLINE DATA
CLASS 1 - FLAT ROOT SIDE FIT
J498b - PITCH 12/24
14 TEETH - 30° PRESSURE ANGLE

T7BB - Ordering Code & Dimensions

T7, Denison Vane Pumps

Model No. **T7BB - E10 - E10 - 5 R 00 - A 1 - MW - M**

T7BB series - 100 A2 HW
ISO 2 bolts 3019-2 mounting flange

Displacement P1 & P2
Volumetric displacement (cm³/rev.)

E03 = 9,8	E09 = 28,0
E04 = 12,8	E10 = 31,8
E05 = 15,9	E11 = 35,0
E06 = 19,8	E12 = 41,0
E07 = 22,5	E14 = 45,0
E08 = 24,9	E15 = 50,0

Type of shaft
5 = keyed (ISO R775)

Direction of rotation (shaft end view)
R = Clockwise
L = Counter-clockwise

Modifications
Ex : NOP = Not painted

Ports
MW = 4 bolts SAE flange J518 with Metric threads
S = 2.1/2"
P1 = 1"
P2 = 1"

Seal class
1 = S1 BUNA N - 0,7 bar max. (for mineral oil)
4 = S4 EPDM - 0,7 bar max. (for fire resistant fluids)
5 = S5 VITON® - 0,7 bar max. (for mineral oil and fire resistant fluids)

Design letter

Porting combination (see page 24)
00 = standard

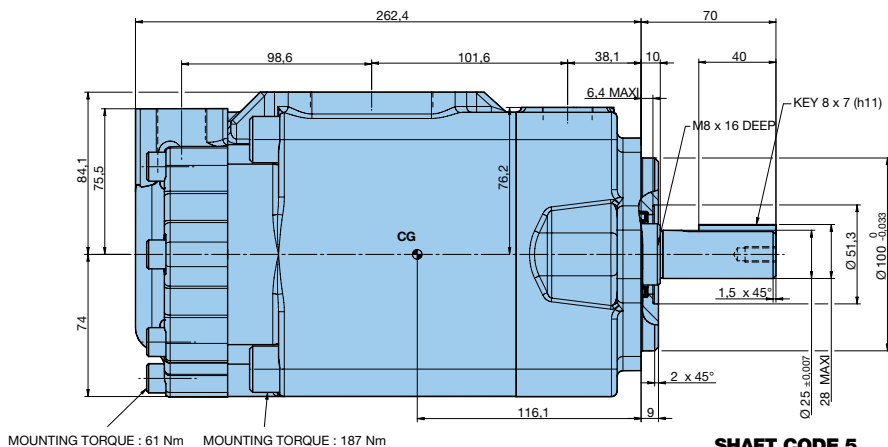
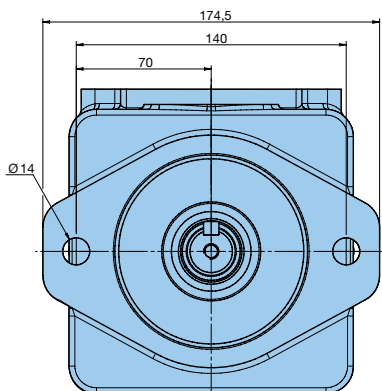

MOUNTING TORQUE : 61 Nm MOUNTING TORQUE : 187 Nm

SHAFT CODE 5
(KEYED ISO R775)

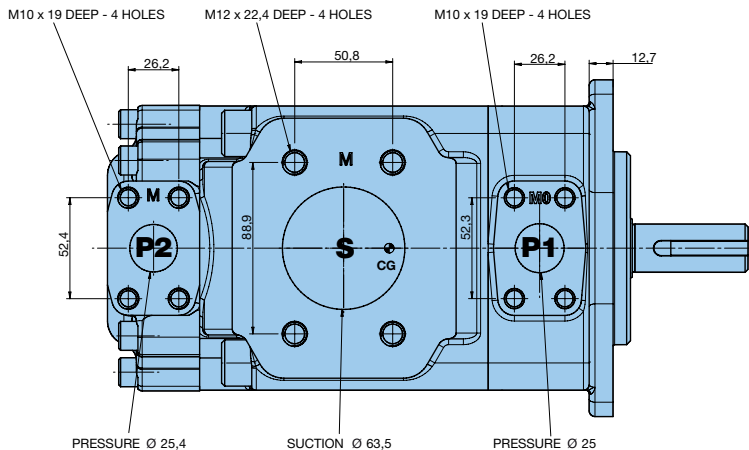

Model No. T7BBS - E10 - E10 - 2 R 00 - A 1 - MW - M

T7BBS series - SAE B 2 bolts
J744 mounting flange

P1 P2

Displacement P1 & P2
Volumetric displacement (cm³/rev.)

E03 = 9,8 E09 = 28,0
E04 = 12,8 E10 = 31,8
E05 = 15,9 E11 = 35,0
E06 = 19,8 E12 = 41,0
E07 = 22,5 E14 = 45,0
E08 = 24,9 E15 = 50,0

Type of shaft

2 = keyed (SAE BB)
3 = splined 16/32 (SAE B) 13 teeth

Direction of rotation (shaft end view)

R = Clockwise
L = Counter-clockwise

Modifications

Ex : NOP = Not painted

Ports

MW = 4 bolts SAE flange J518 with Metric threads
0W = 4 bolts SAE flange J518 with UNC threads
S = 2.1/2"
P1 = 1"
P2 = 1"

Seal class

1 = S1 BUNA N - 0,7 bar max. (for mineral oil)
4 = S4 EPDM - 0,7 bar max. (for fire resistant fluids)
5 = S5 VITON® - 0,7 bar max. (for mineral oil and fire resistant fluids)

Design letter

Porting combination (see page 24)

00 = standard

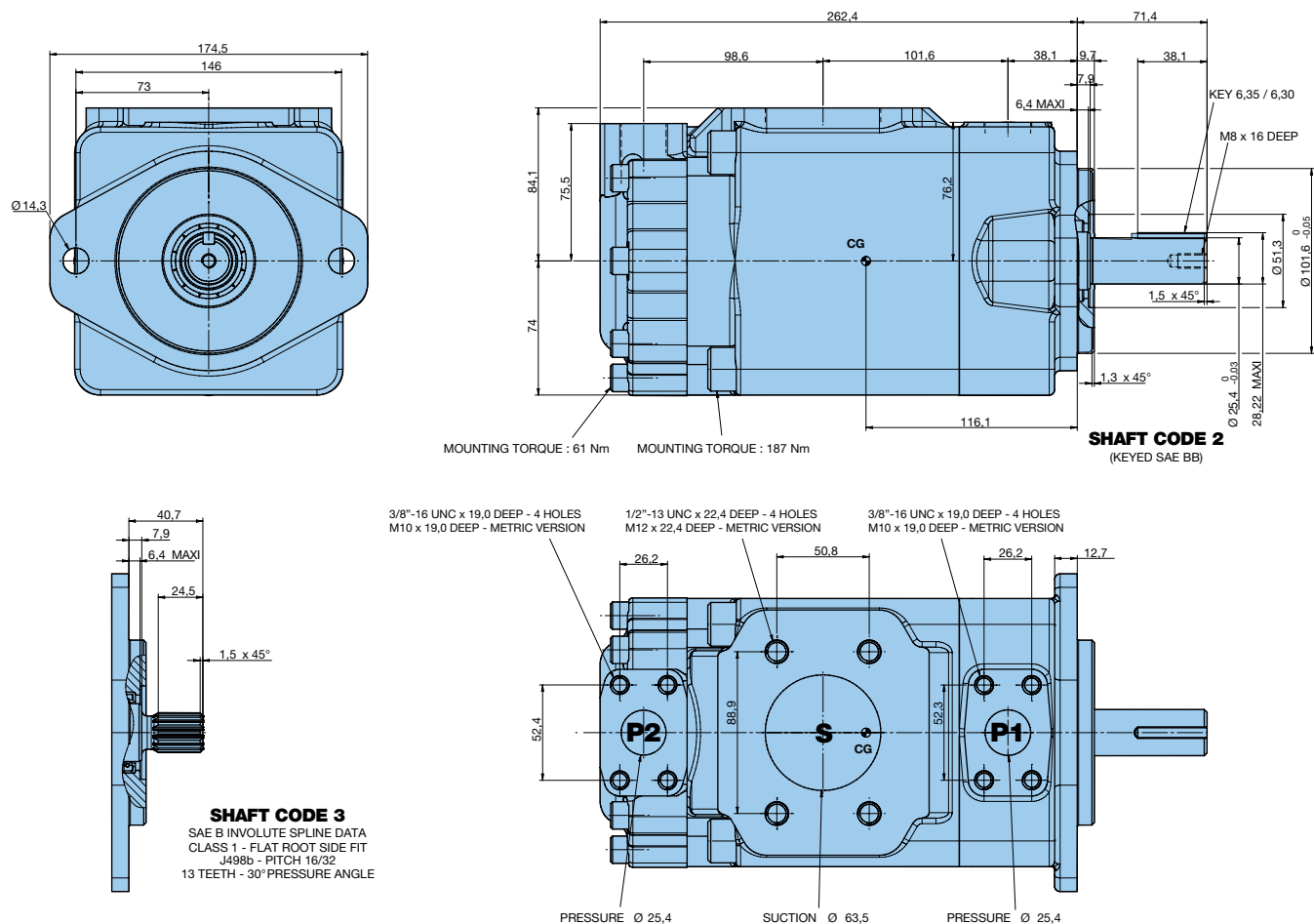

Model No.

T7DB - E42 - E10 - 5 R 00 - A 1 M0 - M

T7DB series - 125 A2 HW
ISO 2 bolts 3019-2 mounting flange

Displacement P1

Volumetric displacement (cm³/rev.)
E14 = 44,0 E28 = 90,0
E17 = 55,0 E31 = 99,2
E20 = 66,0 E35 = 113,4
E22 = 70,3 E38 = 120,6
E24 = 81,1 E42 = 137,5

Displacement P2

Volumetric displacement (cm³/rev.)
E03 = 9,8 E09 = 28,0
E04 = 12,8 E10 = 31,8
E05 = 15,9 E11 = 35,0
E06 = 19,8 E12 = 41,0
E07 = 22,5 E14 = 45,0
E08 = 24,9 E15 = 50,0

Type of shaft

5 = keyed (ISO 3019 -2 - G32 M)

Modifications

Ex : NOP = Not painted

Ports

M0 = 4 bolts SAE flanges J518 with Metric threads
S = 3"
P1 = 1.1/4"
P2 = 1"

Seal class

1 = S1 BUNA N - 0,7 bar max. (for mineral oil)
4 = S4 EPDM - 7 bar max. (for fire resistant fluids)
5 = S5 VITON® - 7 bar max. (for mineral oil and fire resistant fluids)

Design letter

Porting combination (see page 24)

00 = standard

Direction of rotation (shaft end view)

R = Clockwise
L = Counter-clockwise

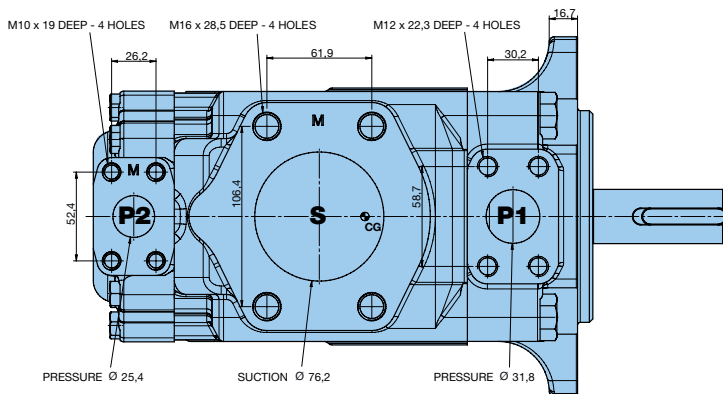
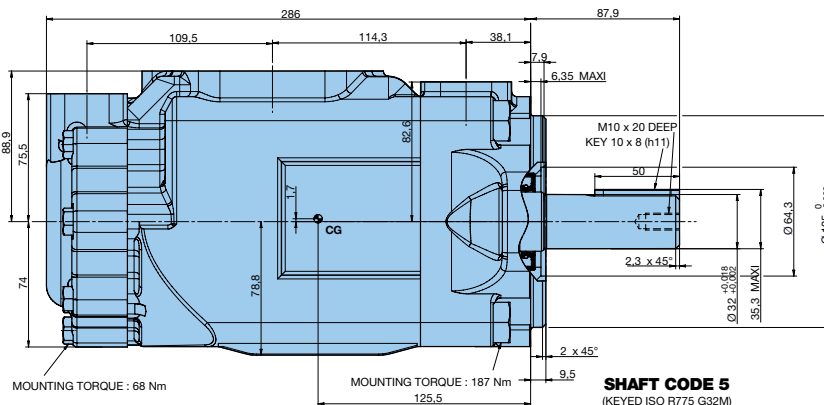
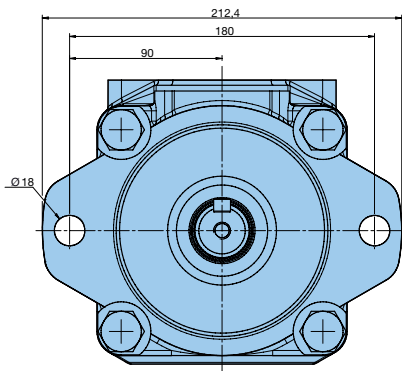

Model No. T7DBS - E42 - E10 - 1 R 00 - A 1 M0 - M

T7DBS series - SAE C 2 bolts
J744 mounting flange

Displacement P1

Volumetric displacement (cm³/rev.)

E14 = 44,0	E28 = 90,0
E17 = 55,0	E31 = 99,2
E20 = 66,0	E35 = 113,4
E22 = 70,3	E38 = 120,6
E24 = 81,1	E42 = 137,5

Displacement P2

Volumetric displacement (cm³/rev.)

E03 = 9,8	E09 = 28,0
E04 = 12,8	E10 = 31,8
E05 = 15,9	E11 = 35,0
E06 = 19,8	E12 = 41,0
E07 = 22,5	E14 = 45,0
E08 = 24,9	E15 = 50,0

Type of shaft

1 = keyed (SAE C)
3 = splined 12/24 (SAE C) 14 teeth

Modifications

Ex : NOP = Not painted

Ports

M0 = 4 bolts SAE flange J518 with Metric threads
00 = 4 bolts SAE flange J518 with UNC threads
S = 3"
P1 = 1.1/4"
P2 = 1"

Seal class

1 = S1 BUNA N - 0,7 bar max. (for mineral oil)
4 = S4 EPDM - 7 bar max. (for fire resistant fluids)
5 = S5 VITON® - 7 bar max. (for mineral oil and fire resistant fluids)

Design letter

Porting combination (see page 24)

00 = standard

Direction of rotation (shaft end view)

R = Clockwise
L = Counter-clockwise

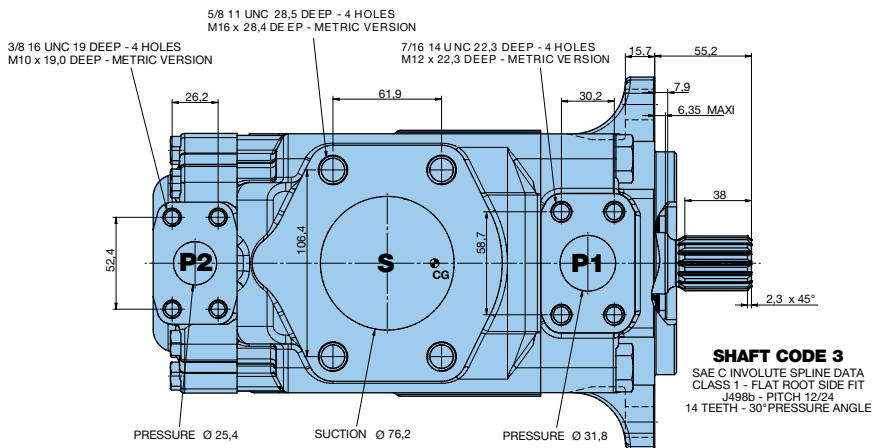
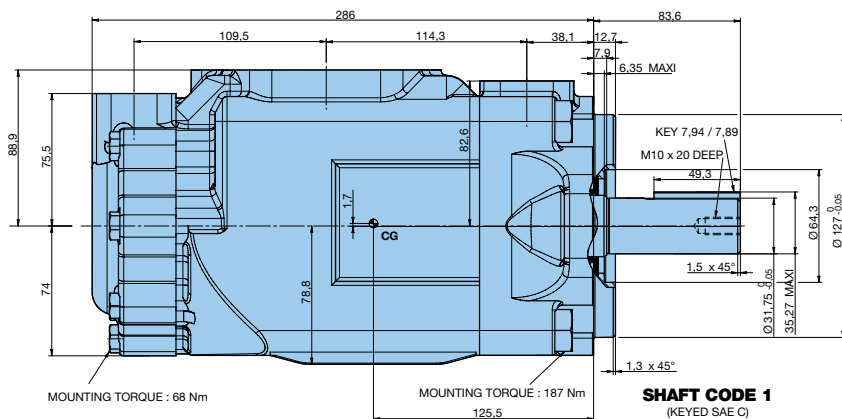
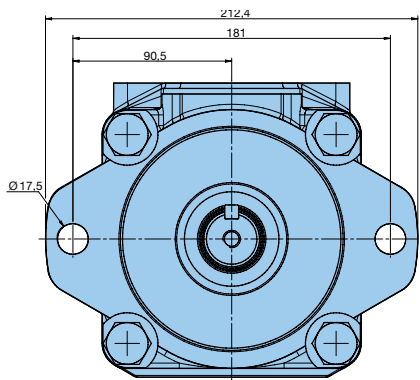

Model No.

T7DD - E42 - E22 - 5 R 00 - A 1 M0 - M

T7DD series - 125 B4 HW
ISO 4 bolts 3019-2 mounting flange

P1 P2

Modifications

Ex : NOP = Not painted

Ports

M0 = 4 bolts SAE flanges J518 with Metric threads
S = 4"
P1 & P2 = 1.1/4"

Displacement P1 & P2

Volumetric displacement (cm³/rev.)

E14 = 44,0 E28 = 90,0
E17 = 55,0 E31 = 99,2
E20 = 66,0 E35 = 113,4
E22 = 70,3 E38 = 120,6
E24 = 81,1 E42 = 137,5

Seal class

1 = S1 BUNA N - 0,7 bar max. (for mineral oil)
4 = S4 EPDM - 7 bar max. (for fire resistant fluids)
5 = S5 VITON® - 7 bar max. (for mineral oil and fire resistant fluids)

Type of shaft

5 = keyed (ISO 3019 -2 - G32 M)

Design letter

Direction of rotation (shaft end view)

R = Clockwise

L = Counter-clockwise

Porting combination (see page 24)

00 = standard

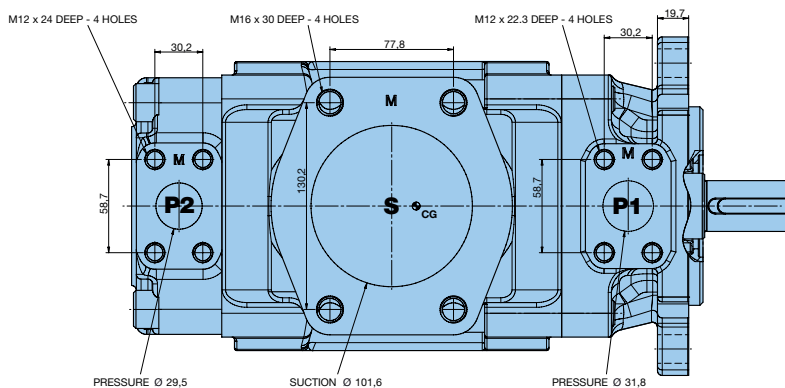
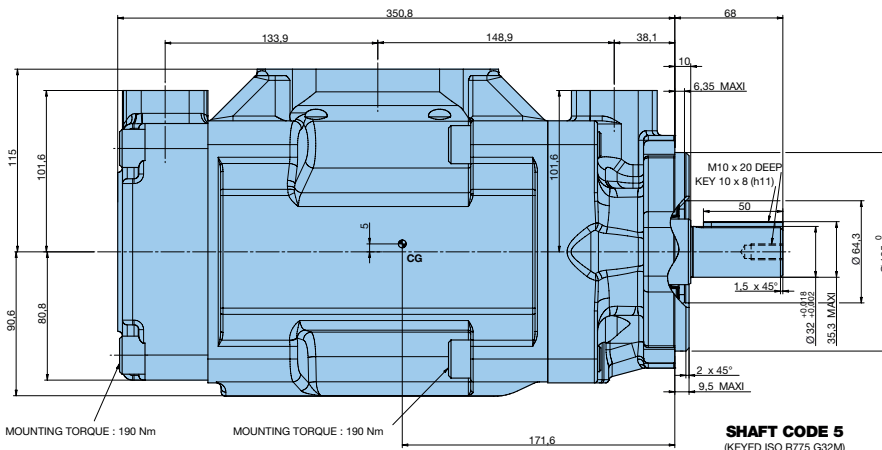
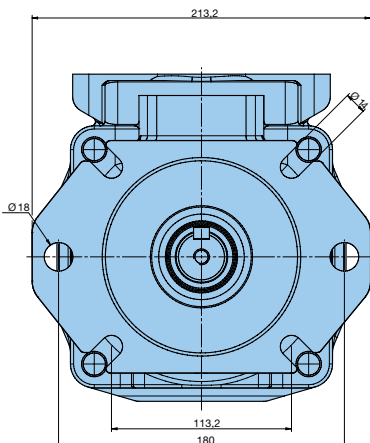

Model No. T7DDS - E42 - E22 - 1 R 00 - A 1 M0 - M

T7DDS series - SAE C 6 bolts
J744 mounting flange

Displacement P1 & P2
Volumetric displacement (cm³/rev.)
E14 = 44,0 E28 = 90,0
E17 = 55,0 E31 = 99,2
E20 = 66,0 E35 = 113,4
E22 = 70,3 E38 = 120,6
E24 = 81,1 E42 = 137,5

Type of shaft
1 = keyed (SAE C)
2 = keyed (SAE CC)
3 = splined 12/24 (SAE C) 14 teeth
4 = splined 16/32 (SAE BB) 15 teeth

Direction of rotation (shaft end view)
R = Clockwise
L = Counter-clockwise

Modifications
Ex : NOP = Not painted

Ports
M0 = 4 bolts SAE flanges J518 with Metric threads
00 = 4 bolts SAE flange J518 with UNC threads
S = 4"
P1 & P2 = 1.1/4"

Seal class
1 = S1 BUNA N - 0,7 bar max. (for mineral oil)
4 = S4 EPDM - 7 bar max. (for fire resistant fluids)
5 = S5 VITON® - 7 bar max. (for mineral oil and fire resistant fluids)

Design letter

Porting combination (see page 24)
00 = standard

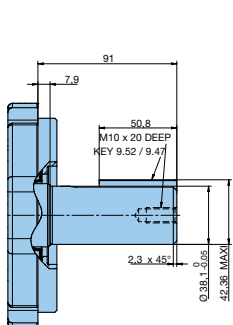
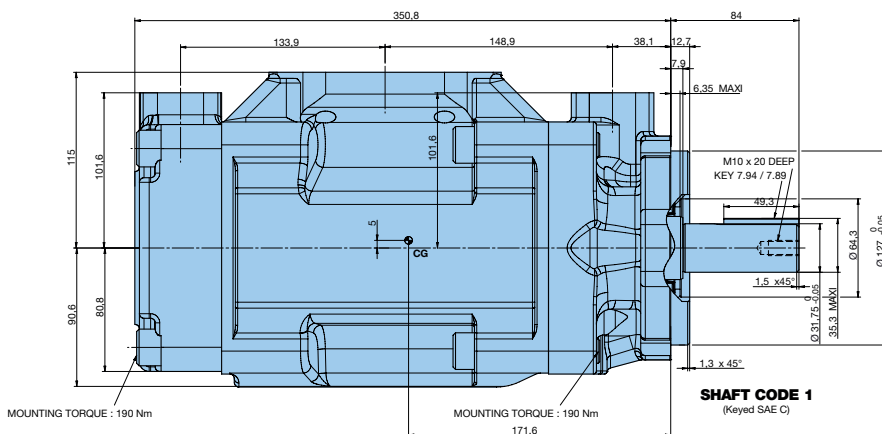
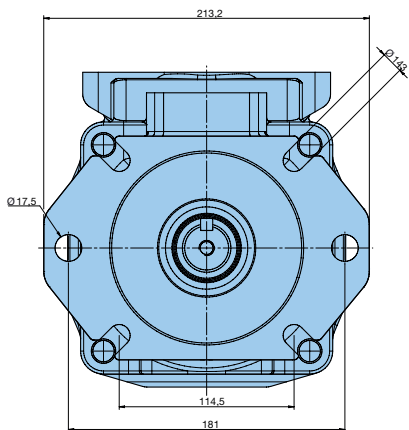

SHAFT CODE 2
(KEYED SAE CC)

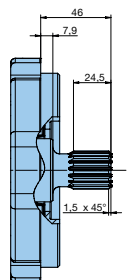

SHAFT CODE 4
SAE BB INVOLUTE SPLINE DATA
CLASS 1 - FLAT ROOT SIDE FIT
4498b - PITCH 16/32
15 TEETH - 30° PRESSURE ANGLE

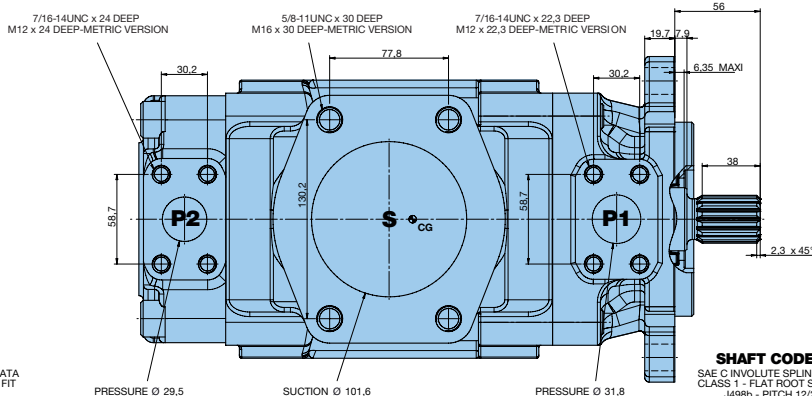

SHAFT CODE 3
SAE C INVOLUTE SPLINE DATA
CLASS 1 - FLAT ROOT SIDE FIT
4498b - PITCH 12/24
14 TEETH - 30° PRESSURE ANGLE

Ordering Code

T7, Denison Vane Pumps

Porting diagrams for double pumps

Pump type	00	01	02	03	04	05	06	07
	P1-P2 	P1-P2 	S-P1-P2 	P1-P2 	P1 	P1 	P1 	P1-S
T7BB								
T7BBS	08	09	10	11	12	13	14	15
T7DB	P1-S 	P1-S 	P1 	P1 	P1 	P1 	P1 	P1
T7DBS								
	16	17	18	19	20	21	22	23
	P1 	P1 	P1 	P1 	P1 	P1 	P1 	P1
	24	25	26	27	28	29	30	31
	P1-S 	P1-S 	P1-S 	P1-S 	P1 	P1 	P1 	P1
Pump type	00	01	02	03	04	05	06	07
T7DD	P1-P2 	P1-P2 	S-P1-P2 	P1-P2 	P1 	P1 	P1 	P1-S
T7DDS	08	09	10	11	12	13	14	15
	P1-S 	P1-S 	P1 	P1 	P1 	P1 	P1 	P1

T7A - T7AS

Internal leakage (Typical)

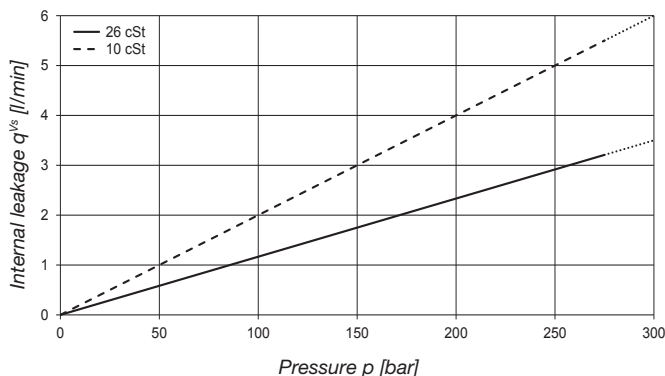

Noise level (Typical)
T7A - T7AS - E20

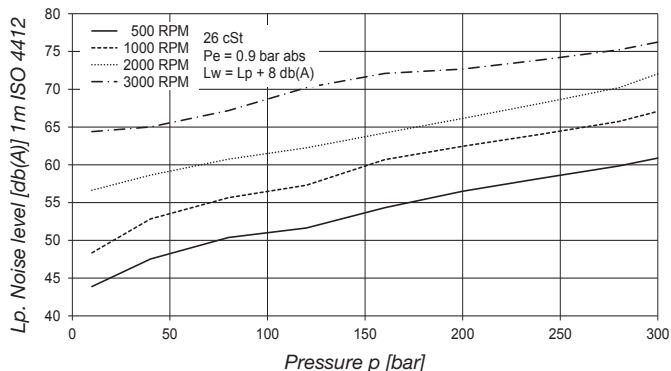

Power loss hydromechanical (Typical)

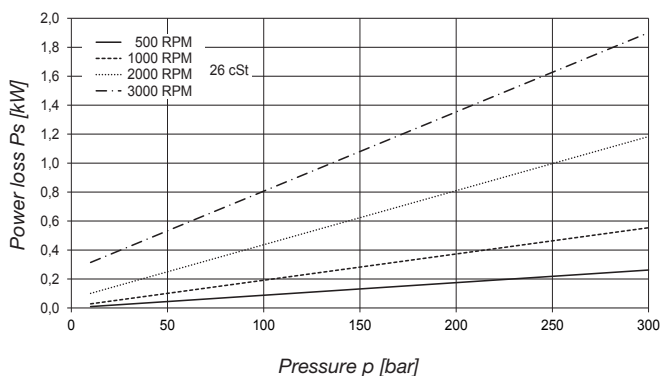

Torque loss hydromechanical (Typical)

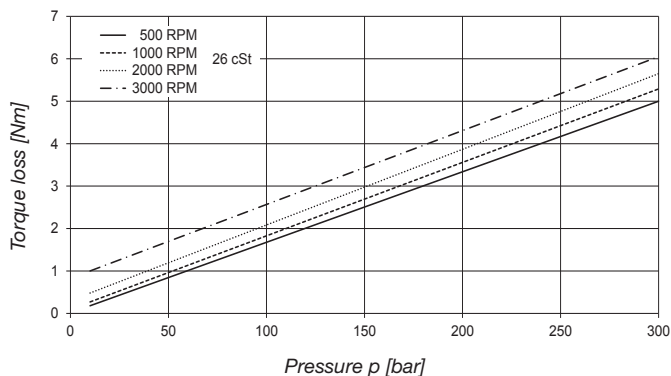

Permissible radial load

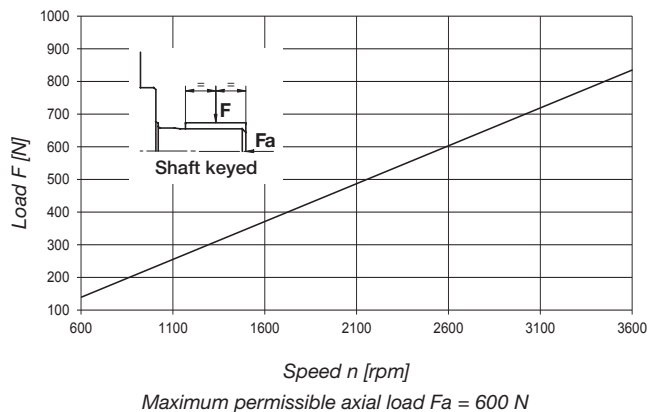

Pump information

Pump type : T7A - T7AS
 Weight : 9,5 kg
 Moment of inertia : 2,6 Kg^m x 10⁻⁴
 Input torque limit :

Shaft	Vi [cm ³ /rev] x p max. [bar]	Nm
1	8720	138
2	8720	138
3	8720	138
4	6550	104

T7ASW

Internal leakage (Typical)

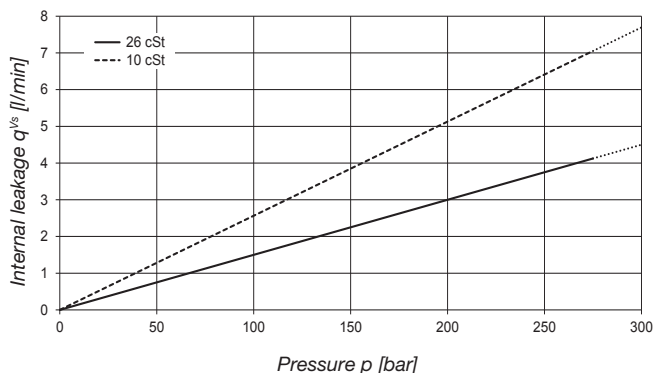

Noise level (Typical)
T7ASW - E40

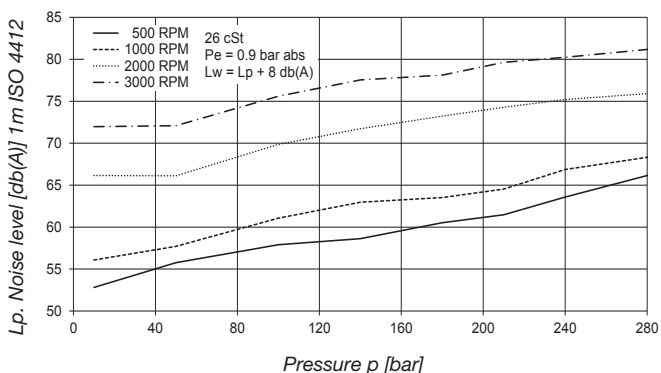

Power loss hydromechanical (Typical)

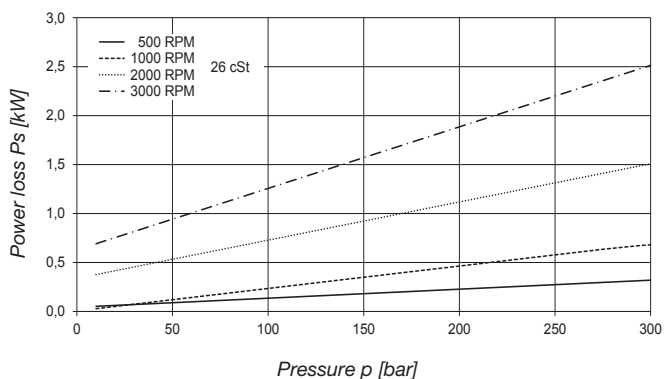

Torque loss hydromechanical (Typical)

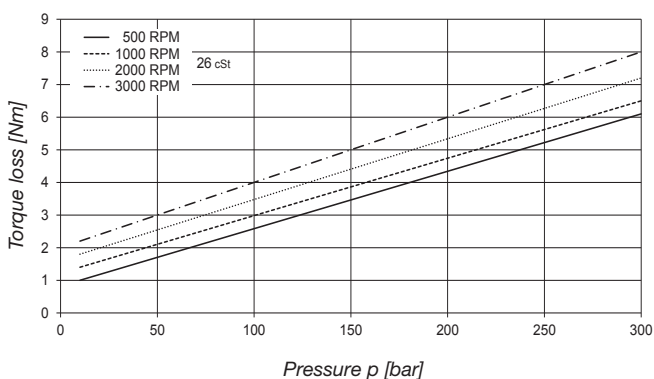

Permissible radial load

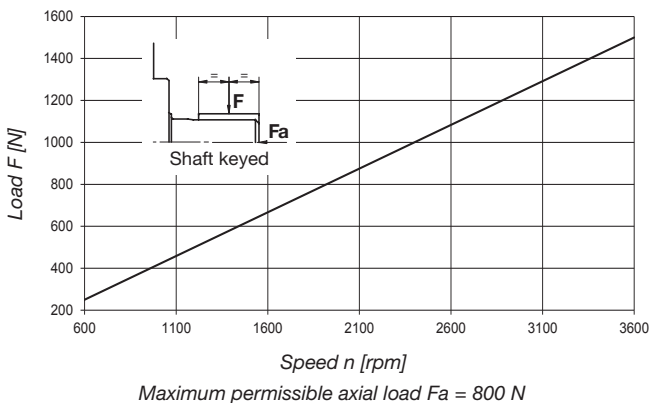

Pump information

Pump type : T7ASW
 Weight : 11,3 kg
 Moment of inertia : $3,2 \text{ Kg} \cdot \text{m}^2 \times 10^{-4}$
 Input torque limit :

Shaft	V_i [cm ³ /rev] x p max. [bar]	Nm
1	18530	294
3	18530	294
4	6550	104

T7B - T7BS

Internal leakage (Typical)

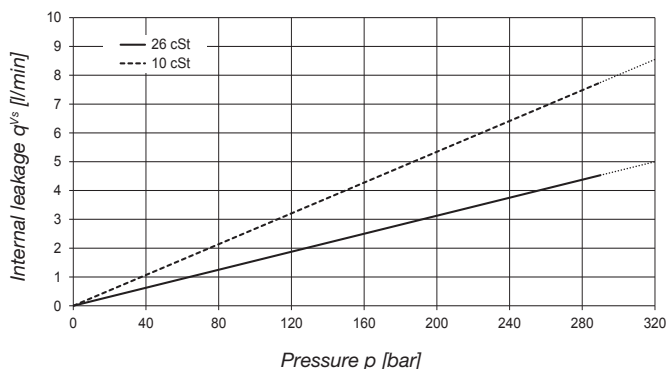

Noise level (Typical)
T7B - T7BS - E10

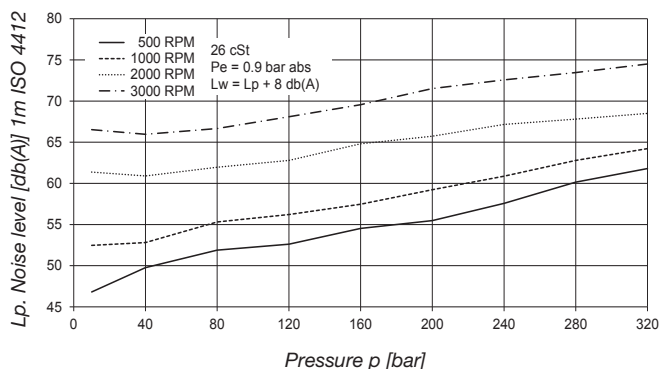

Power loss hydromechanical (Typical)

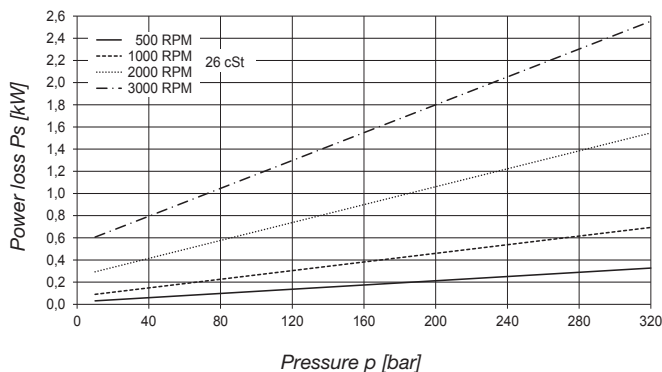

Torque loss hydromechanical (Typical)

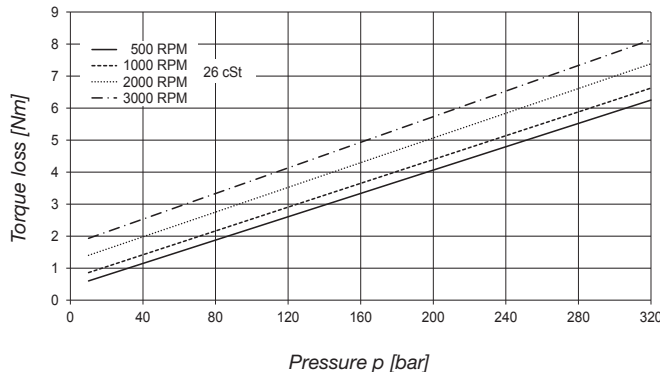

Permissible radial load

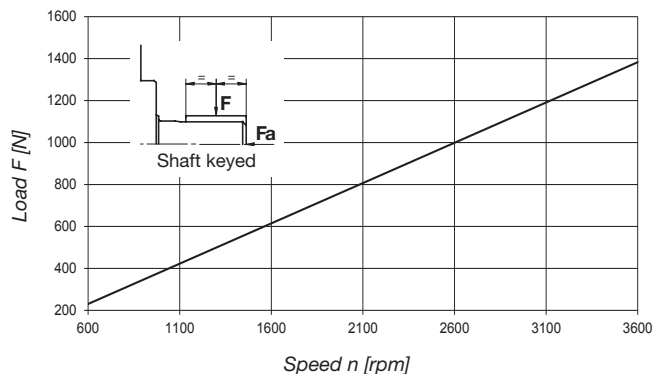

Maximum permissible axial load Fa = 800 N

Pump information

Pump type : T7B - T7BS
 Weight : 23,0 kg
 Moment of inertia : 3,2 Kg^{m2} x 10⁻⁴
 Input torque limit :

Shaft	Vi [cm ³ /rev] x p max. [bar]	Nm
1	16500	262
2	20600	327
3	20600	327
4	20600	327

T7D - T7DS

Internal leakage (Typical)

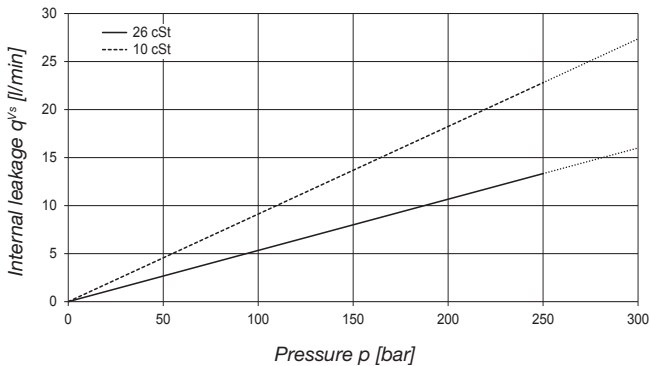

**Noise level (Typical)
T7D - T7DS - E38**

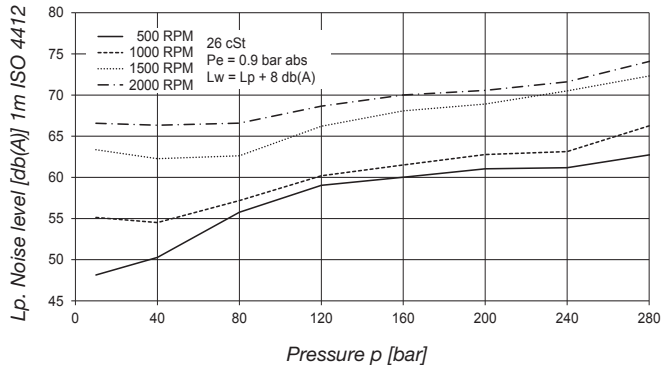

Power loss hydromechanical (Typical)

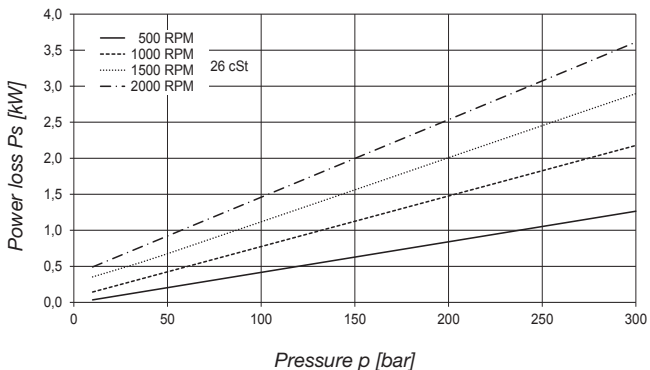

Torque loss hydromechanical (Typical)

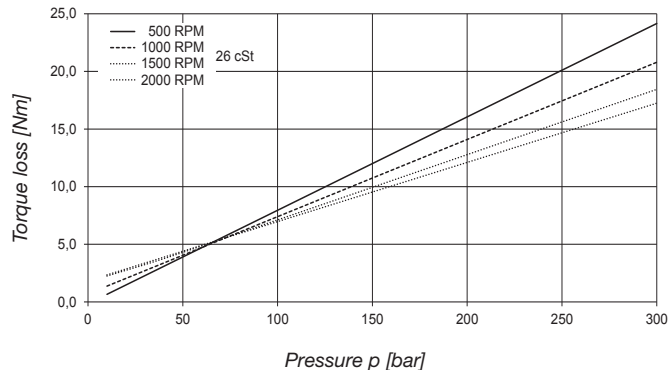

Permissible radial load

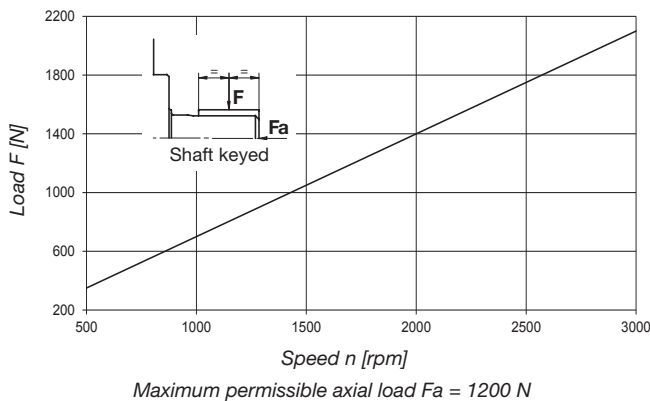

Pump information

Pump type : T7D - T7DS
Weight : 26,0 kg
Moment of inertia : 19,6 Kg $m^2 \times 10^{-4}$
Input torque limit :

Shaft	V_i [cm ³ /rev] x p max. [bar]	Nm
1	43240	688
3	61200	974
5	44300	705

T7BB - T7BBS

Internal leakage (Typical)

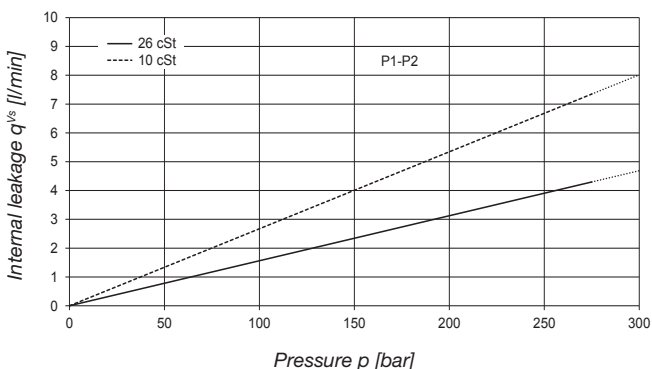

Total leakage is the sum of each section loss under its respective operating conditions.

Noise level (Typical)
T7BB - T7BBS - E10 - E08

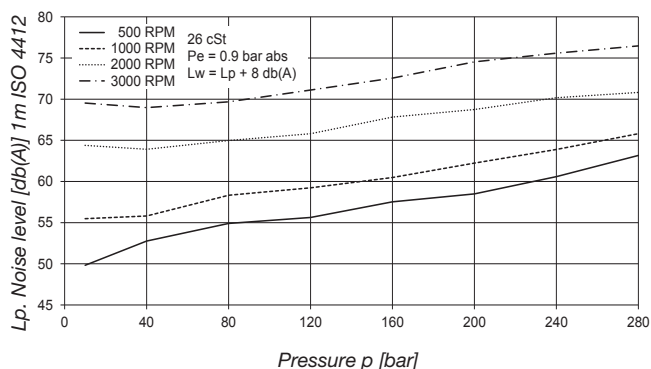

Double pump noise level is given with both stages discharging at the pressure value indicated on the curve.

Power loss hydromechanical (Typical)

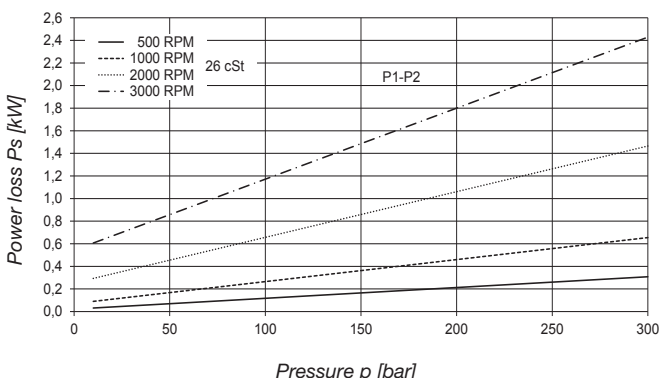

Total hydromechanical power loss is the sum of each section loss under its respective operating conditions.

Torque loss hydromechanical (Typical)

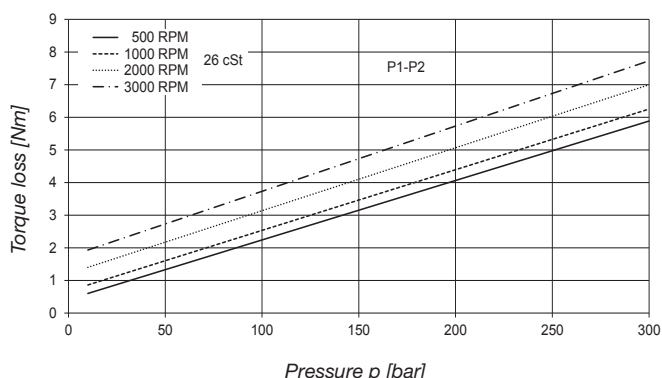

Permissible radial load

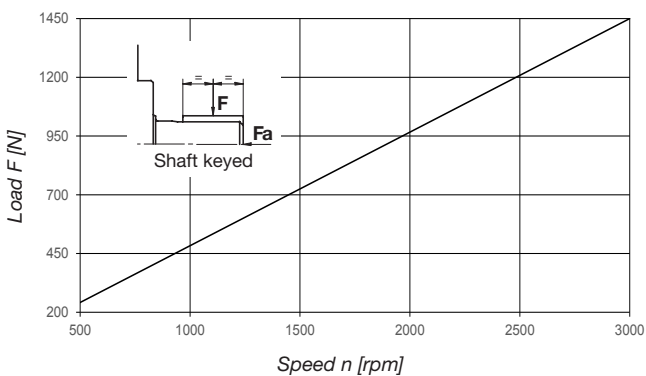

Maximum permissible axial load $F_a = 1200\text{ N}$

Pump information

Pump type : T7BB - T7BBS
Weight : 32,6 kg
Moment of inertia : $6,7\text{ Kg}\cdot\text{m}^2 \times 10^{-4}$
Input torque limit :

Shaft	V_i [cm^3/rev] x p max. [bar]	Nm
2	21420	340
3	20600	327
5	25300	402

T7DB - T7DBS

Internal leakage (Typical)

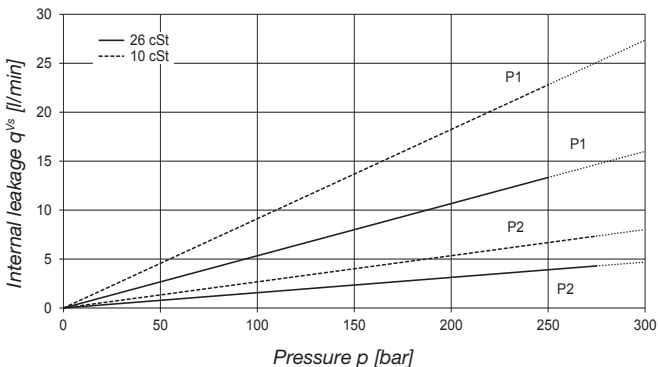

Total leakage is the sum of each section loss under its respective operating conditions.

Noise level (Typical)
T7DB - T7DBS - E38 - E10

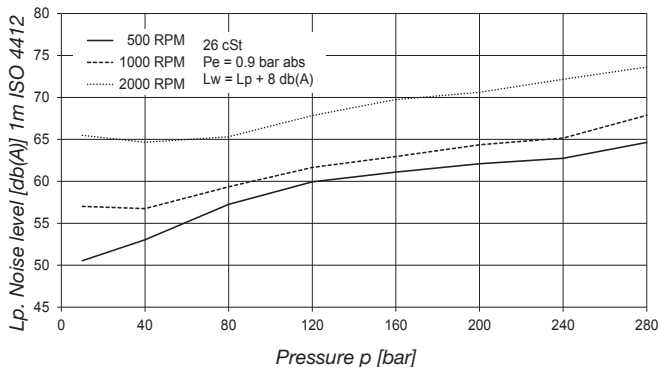

Double pump noise level is given with both stages discharging at the pressure value indicated on the curve.

Power loss hydromechanical (Typical)

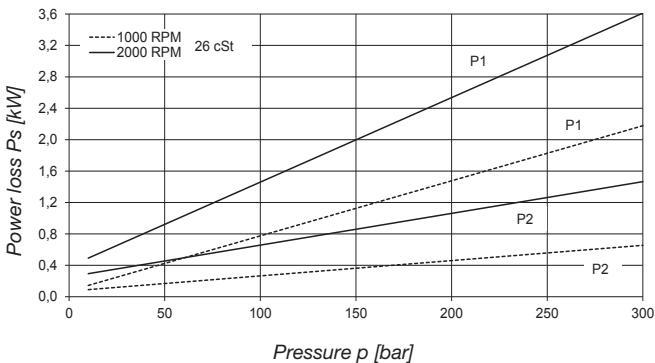

Total hydromechanical power loss is the sum of each section loss under its respective operating conditions.

Torque loss hydromechanical (Typical)

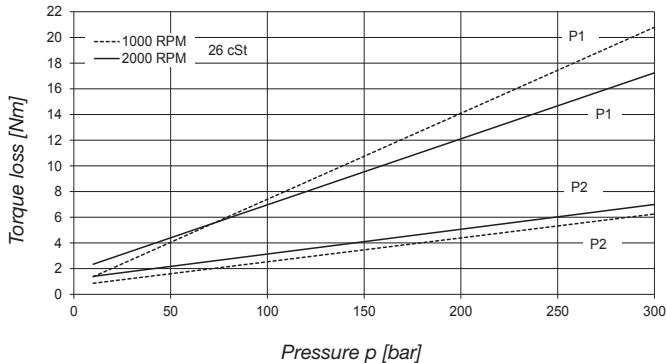

Permissible radial load

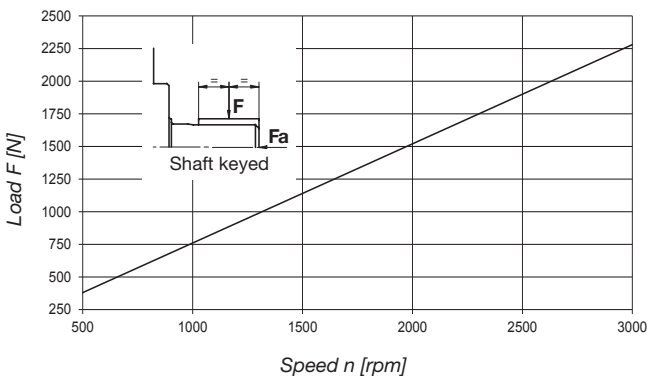

Maximum permissible axial load $F_a = 1200\text{ N}$

Pump information

Pump type : T7DB - T7DBS
 Weight : 38,6 kg
 Moment of inertia : 22,7 Kg $m^2 \times 10^{-4}$
 Input torque limit :

Shaft	V_i [cm 3 /rev] x p max. [bar]	Nm
1	43240	688
3	61200	974
5	42500	676

T7DD - T7DDS

Internal leakage (Typical)

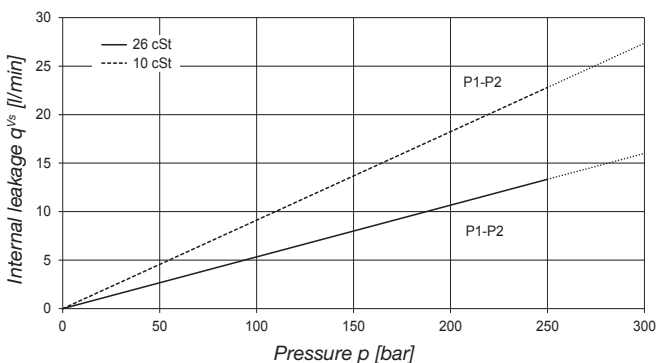

Total leakage is the sum of each section loss under its respective operating conditions.

Noise level (Typical)
T7DD - T7DDS - E38 - E38

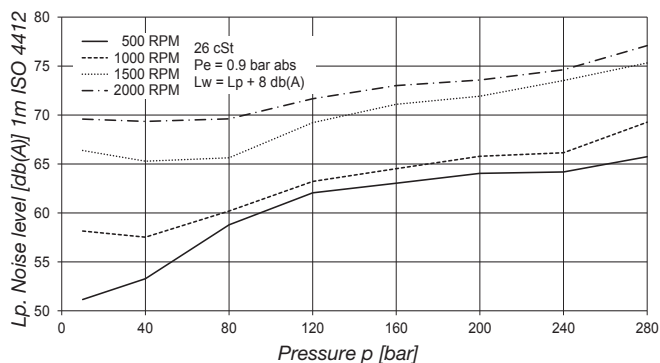

Double pump noise level is given with both stages discharging at the pressure value indicated on the curve.

Power loss hydromechanical (Typical)

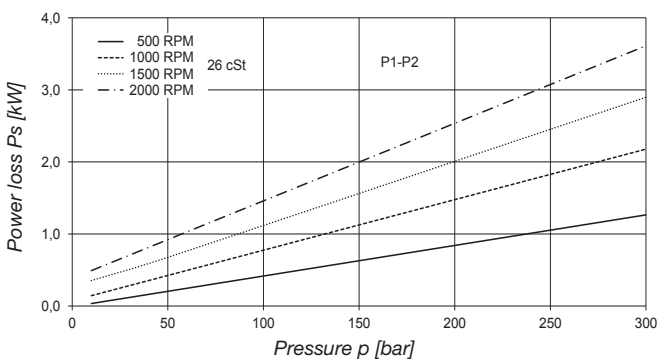

Total hydromechanical power loss is the sum of each section loss under its respective operating conditions.

Torque loss hydromechanical (Typical)

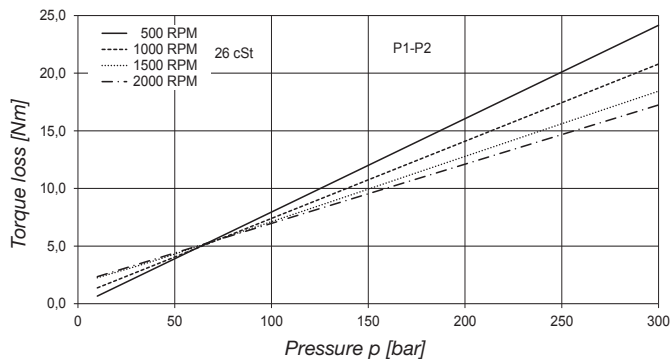

Permissible radial load

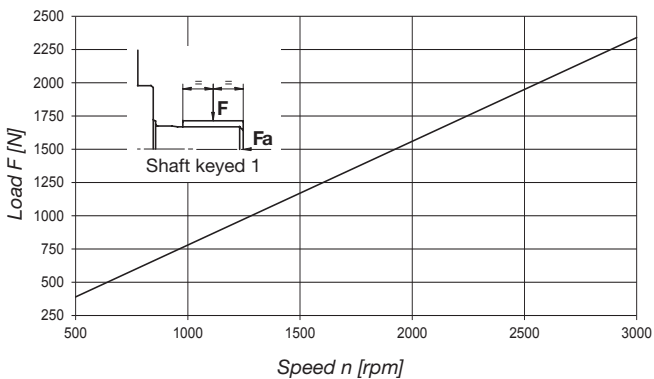

Maximum permissible axial load $F_a = 1200\text{ N}$

Pump information

Pump type : T7DD - T7DDS
Weight : 56,0 kg
Moment of inertia : $36,3\text{ Kg}\cdot\text{m}^2 \times 10^{-4}$
Input torque limit :

Shaft	V_i [cm ³ /rev] x p max. [bar]	Nm
1	43240	688
2	71750	1142
3	61200	974
4	35880	571
5	45200	719

Pump Selection**Pump selection example****1 The starting point is to collect the hydraulic parameters of the machine cycle :**

The fluid type. The duration, the pressure and the flow values.

Example: The fluid is ISO VG32 mineral oil, and the cycle described in a table.

2 Calculate the total time of the cycle and the average pressure of the cycle

Total cycle time = $\sum_{i=1}^N t_i = 0,6 + 0,3 + 1,5 + 1 + 6,5 + 0,3 + 0,6 + 1 = 11,8$ seconds

Average pressure = $\sum_{i=1}^N (p_i \cdot t_i) / \sum_{i=1}^N t_i$

$((110 \times 0,6) + (140 \times 0,3) + (155 \times 1,5) + (110 \times 1) + (105 \times 6,5) + (155 \times 0,3) + (110 \times 0,6) + (50 \times 1)) / 11,8 = 110$ bar

3 First estimation of the pump size based on the flow requirement and a "median Max speed".

Biggest flow requirement = 95 lpm Median Max speed = 2500 rpm

⇒ $95/2500 \times 1000 = 38$ cm³/rev

4 From the catalogue tables, select a pump that can operate with the fluid type of the application at the max pressure and the Median Max speed.

Fluid is HF0- HF2 Mineral oil p max = 155 bar

Median Max speed = 2500 rpm See speed and pressure ratings in the main technical data tables.

⇒ Let's try a T7B E11 pump with $V_i = 35$ cm³/rev which seems to be acceptable

5 Report the flow loss of this pump for each working pressure.

Read T7B flow losses from graphs page 27

- Use 26 or 10 cSt curve depending on the working conditions.

- An average value of the two curves may also be selected

6 Calculate the real flows the pump has to supply for each step of the cycle.

$Q_{real} = Q + q^{vs}$

7 Calculate the pump rotation speed for each step of the cycle.

$n = Q_{real} \times (10^3 / V_i)$

8 Calculate the theoretical torque for each step of the cycle.

$T_{theo.} = (V_i \times p) / (20 \times \pi)$

9 Report the torque loss of this pump for each working pressure and operating speed.

Read T7B torque losses from graph page 27

10 Calculate the real torque requirement for each step of the cycle.

$T_{real} = T_{theo.} + T_{loss.}$

Pump Selection

11 Compare the torque requirements to the maximum input torque of the selected pump.

Maximum input torque for T7B E11 pump with shaft type 2 : Read the technical data on page 27.

Tmax = 327 Nm

Tmax must be highest than the larger of T real. value.

If not, select another pump with a stronger shaft and re start from point 2.

12 Compare the highest rotation speed of the pump during the cycle with the maximum speed rating of the selected pump.

Maximum speed rating of the T7B E11 pump (read the main technical data on page 4) = 3400 rpm.

Maximum speed in cycle = 2800 rpm.

Maximum speed during cycle must be lower than the maximum speed rating of the pump.

If not, select another pump with a higher speed rating or a bigger displacement and re start from point 2.

13 For each cycle step, identify the step operating mode in the pump operating range chart.

Cross pump pressure and speed values on the T7B E11 "pump operating range" chart page 9 : Continuous or Intermittent.

14 For each Intermittent cycle step, verify that the flow requirement Q is acceptable for the respective step duration t.

Read the max possible time duration value in "the time restriction at low flow" chart.

In case the step is not Acceptable, correct the Q value to get an Acceptable cycle step.



T7B E11 vi = 35 cm³/rev	Time t [sec]	Pressure p [bar]	Flow Q [l/min]	Pump losses q ^{vs} [l/min]	Supply flow Q real. [l/min]	Pump speed n [rpm]	T theo. torque [Nm]	T loss. @ p & rpm [Nm]	T real. torque [Nm]	Operating mode	Cycle step status
Mould close	0,6	110	70	2,0	72,0	2050	61,3	3,5	65	C	A
Tonnage	0,3	140	50	2,2	52,2	1500	78,0	4,0	82	C	A
Injection	1,5	155	95	2,8	97,8	2800	86,4	5,0	92	C	A
Injection hold	1,0	110	16	2,0	18,0	500	61,3	2,5	64	C	A
Curing	6,5	105	90	2,0	92,0	2650	58,5	4,0	63	C	A
Decompression	0,3	155	40	2,8	42,8	1250	86,4	4,0	91	C	A
Mould open	0,6	110	50	2,0	52,0	1500	61,3	3,0	65	C	A
Ejection	1,0	50	30	1,0	31,0	900	27,9	2,0	30	C	A
Total cycle	11,8										
Average cycle pressure		110									

The preselection of the pump is now complete.

It is a preselection only as it is now time to find a suitable electric motor to match with the application parameters, and this may lead to reconsider this preselected pump. For the best choice being the best compromise, it may also happen to change the displacement of the preselected pump at the time to fine tune the new complete system.

Parker is also offering a broad range of assembled Drive Controlled Pump systems. In order to easily select these Drive Controlled Pump packages, Parker offers a unique software tool : The DriveCreator. Please consult your local Parker office.

Pump Selection

T7, Denison Vane Pumps

How to use the time restriction tables

1 Graph for pump type T7B E15 : Vi = 50 cm³/rev

Step time duration : 300 sec
 Pressure : 160 bar
 Needed output flow : 4 l/mn
 Continuous Zone = No time restriction

This cycle step is acceptable with
 Pump Min speed = $(Q + q^{vs}) \times (10^3 / V_i)$

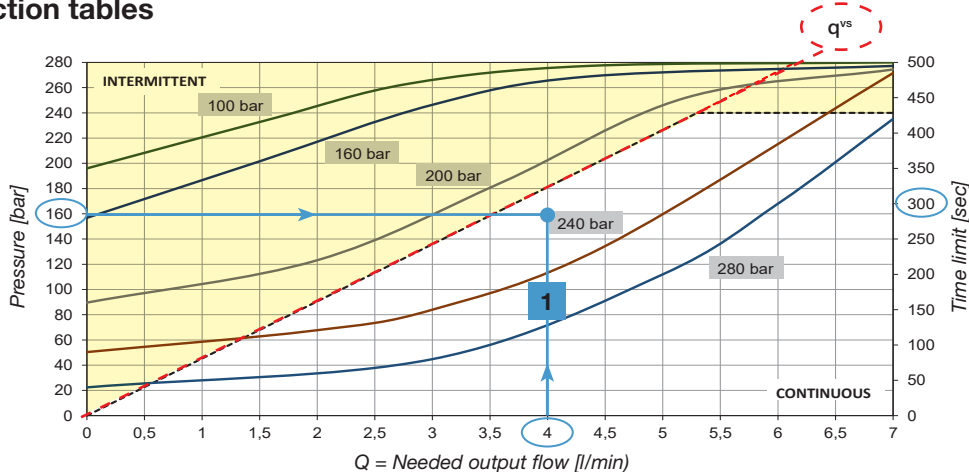

2 Graph for pump type T7B E15 : Vi = 50 cm³/rev

Step time duration : 180 sec
 Pressure : 200 bar
 Needed output flow : 3,5 l/mn
 Intermittent Zone = Time restriction

Read time restriction value for 200 bar curve
 T Max = 325 > 180 sec

This cycle step is acceptable with
 Pump Min speed = $(Q + q^{vs}) \times (10^3 / V_i)$

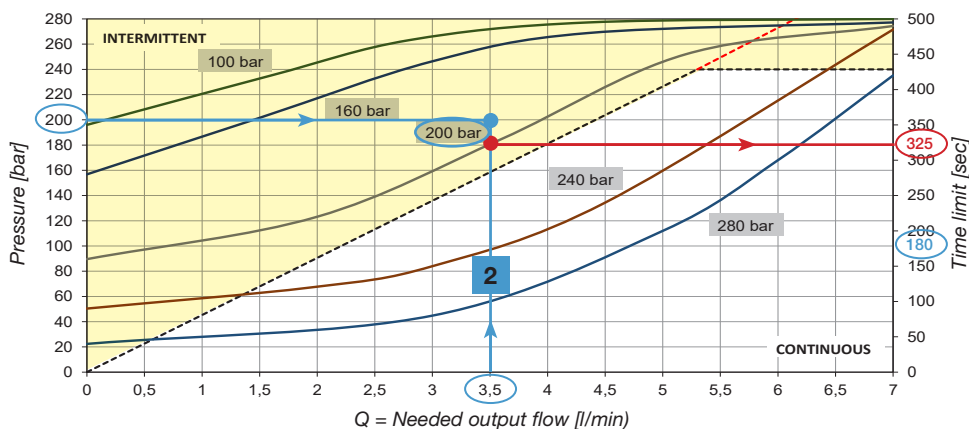

3 Graph for pump type T7B E15 : Vi = 50 cm³/rev

Step time duration : 400 sec
 Pressure : 200 bar
 Needed output flow : 3,5 l/mn
 Intermittent Zone = Time restriction

Read time restriction value for 200 bar curve
 T Max = 325 < 400 sec

This cycle step is not acceptable
 An additional flow amount must be added in order to perform this step.

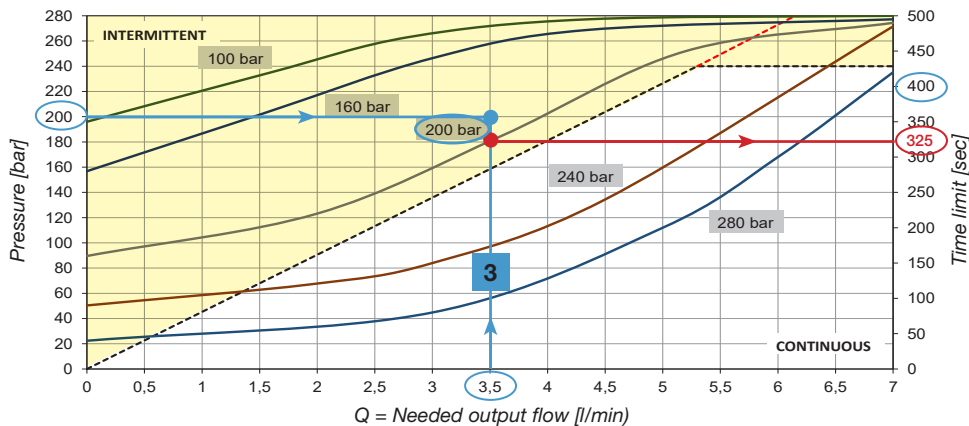

4 Graph for pump type T7B E15 : Vi = 50 cm³/rev

Step time duration : 400 sec
 Pressure : 200 bar
 Needed output flow : ?

Read on the 200 bar curve the needed flow value
 allowing more than 400 sec : 5 l/mn

This cycle step is acceptable with
 Pump Min speed = $(Q + q^{vs}) \times (10^3 / V_i)$

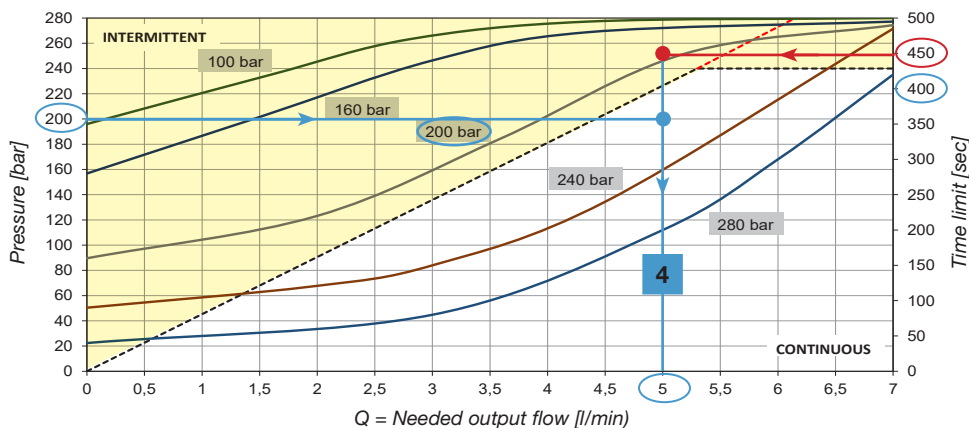

Pump Selection

Time restriction at low flow

**T7A - T7AS
 E06 - E10 - E11 - E13**

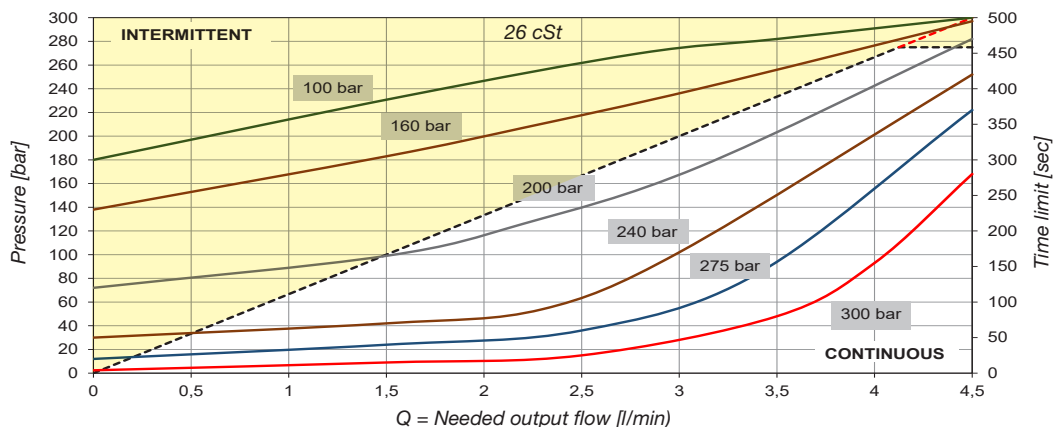

**T7A - T7AS
 E17 - E20 - E22**

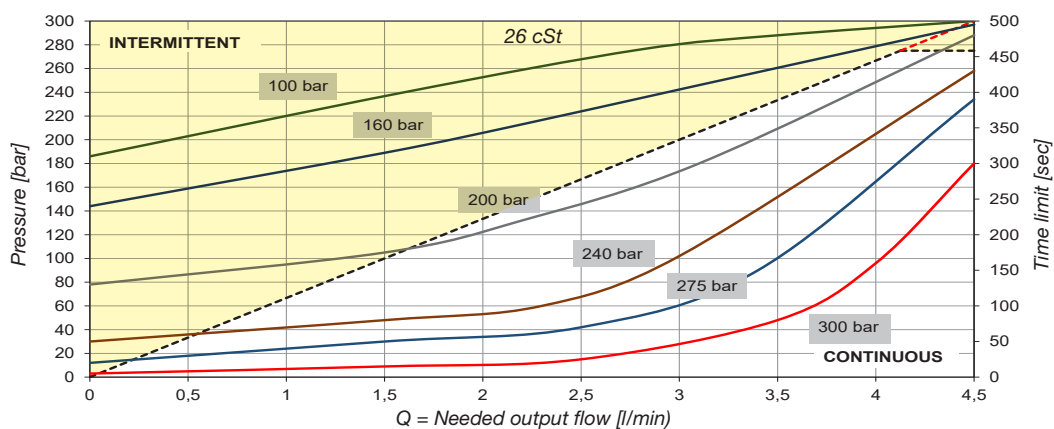

**T7A - T7AS
 E25**

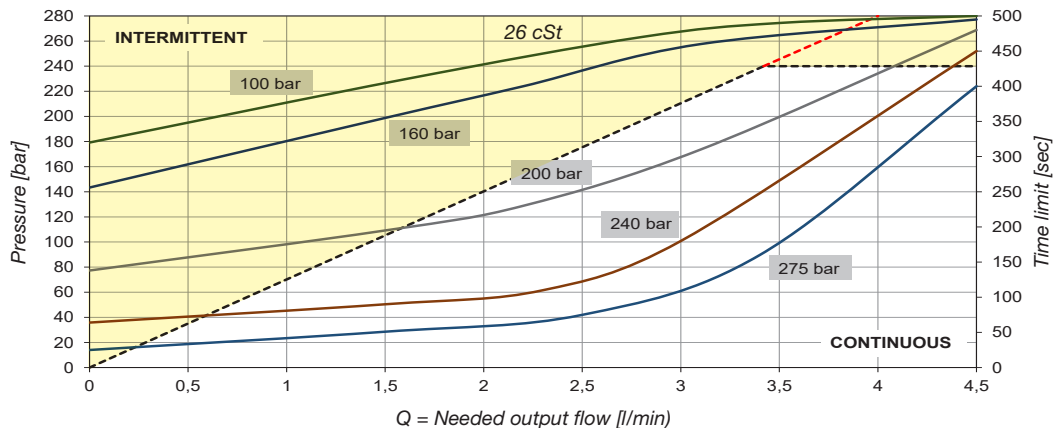

Pump Selection

T7, Denison Vane Pumps

Time restriction at low flow

**T7ASW
E22 - E26 - E28**

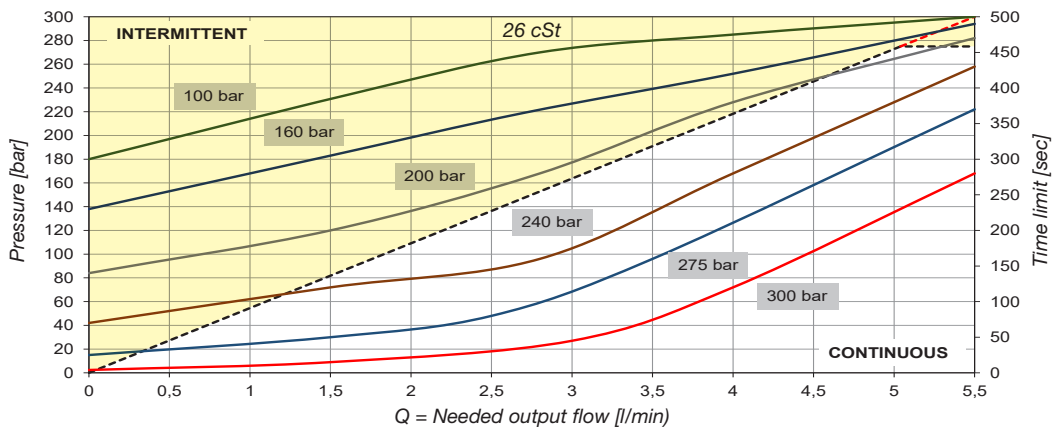

**T7ASW
E30 - E32**

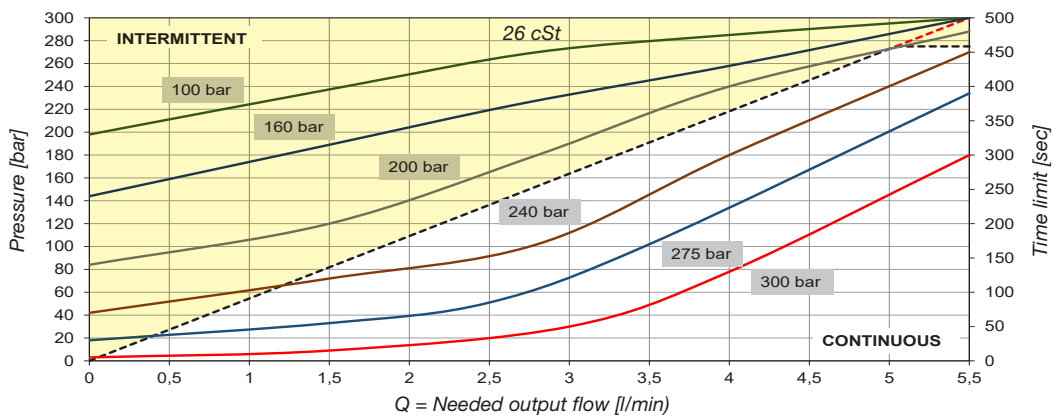

**T7ASW
E35 - E36 - E40**

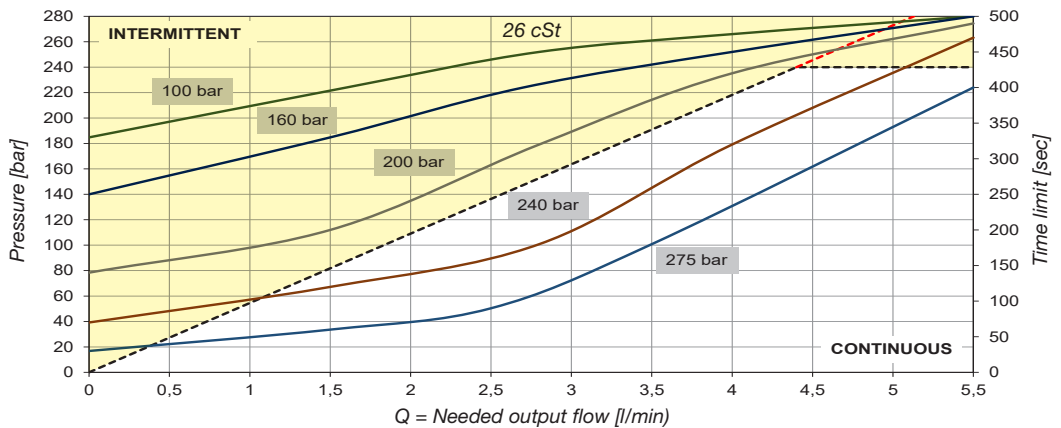

Time restriction at low flow

**T7B - T7BS
E03 - E04 - E05 - E06**

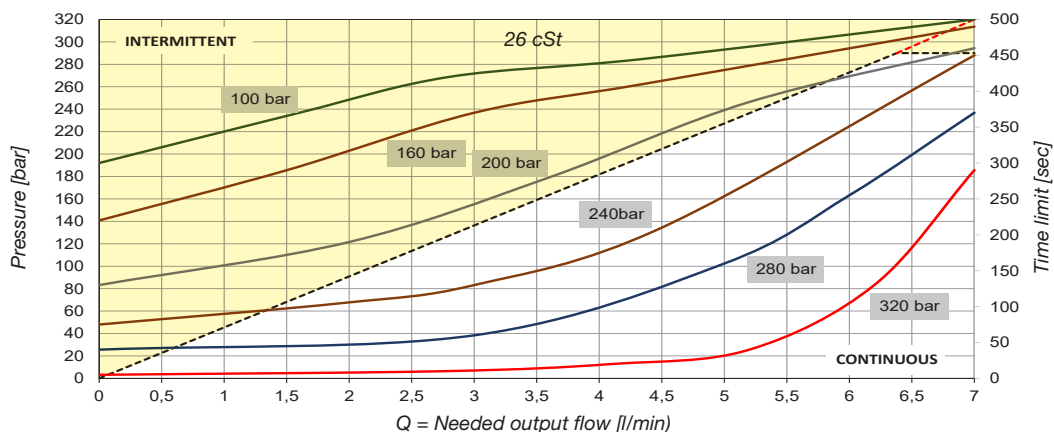

**T7B - T7BS
E07 - E08 - E09 - E10**

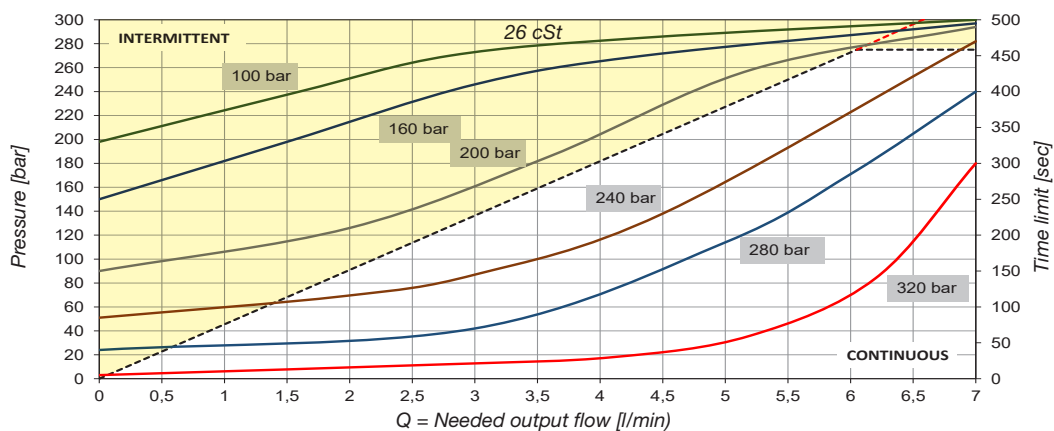

**T7B - T7BS
E11 - E12 - E14**

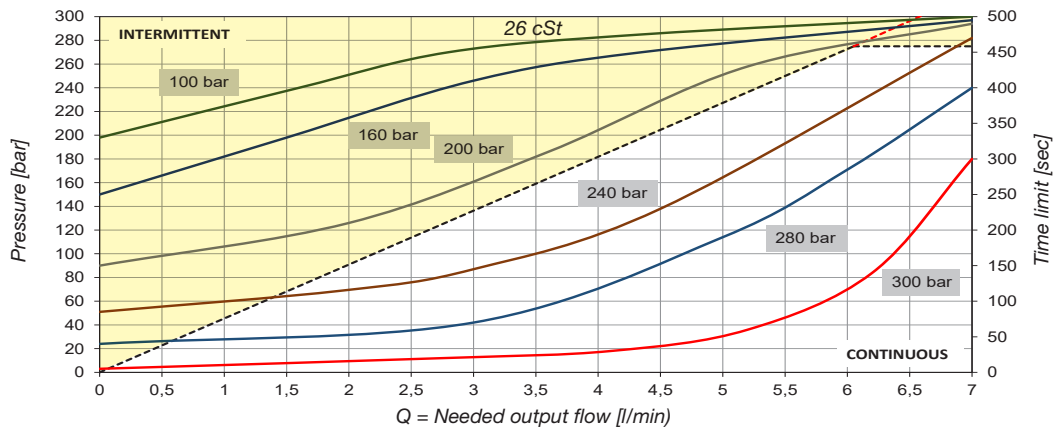

**T7B - T7BS
E15**

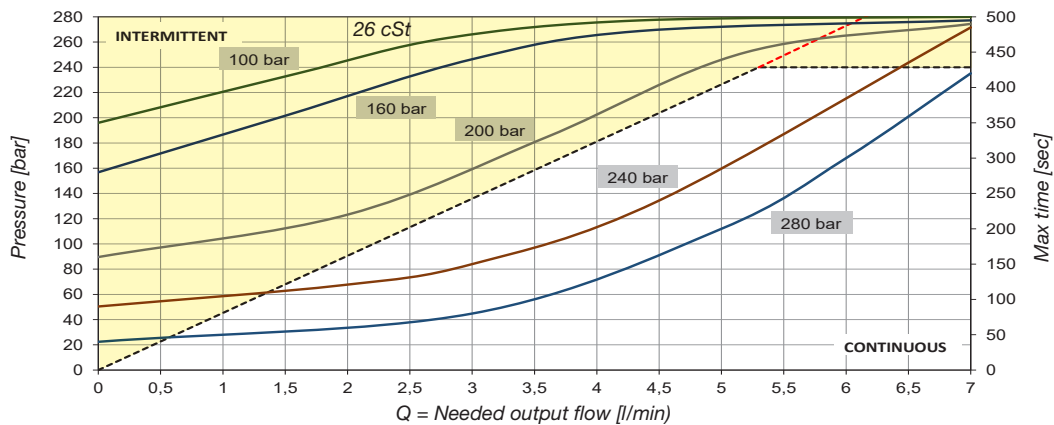

Time restriction at low flow

**T7D - T7DS
E14 - E17 - E20**

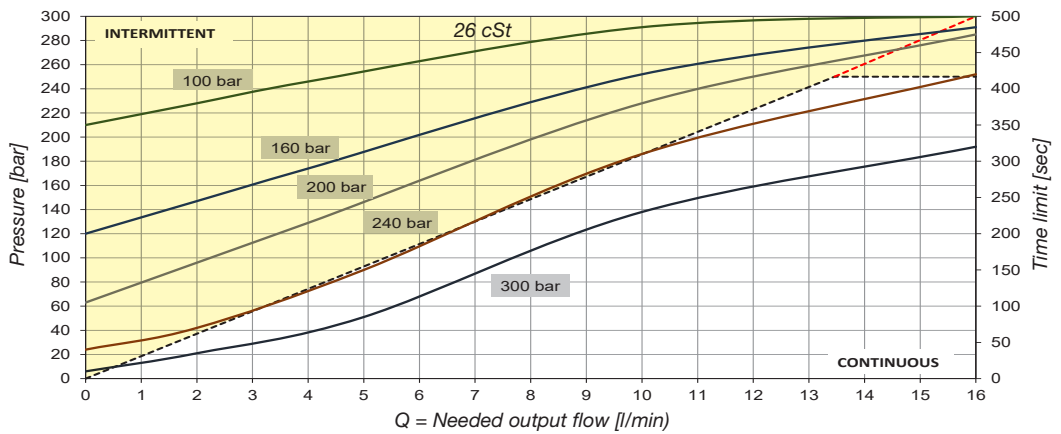

**T7D - T7DS
E22 - E24 - E28 - E31**

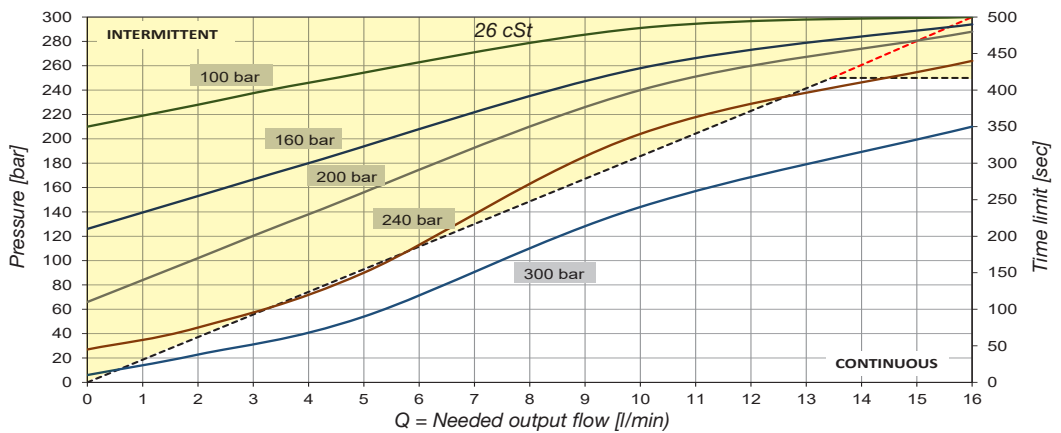

**T7D - T7DS
E35 - E38**

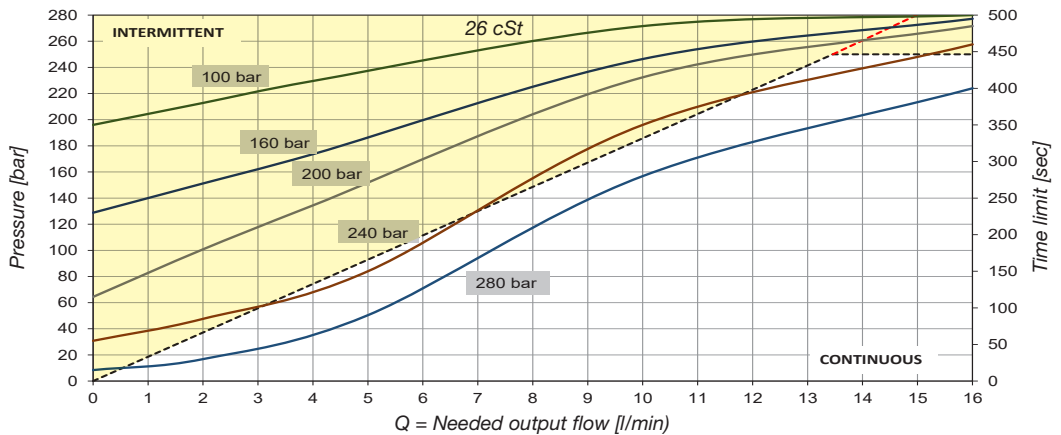

**T7D - T7DS
E42**

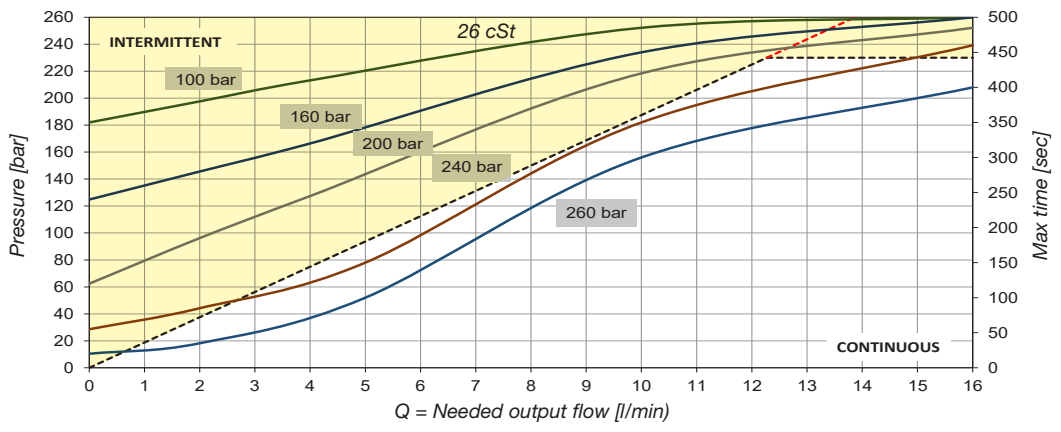

Circuit design

Holding the pressure

When a high pressure has to be held over a long period of time, the design of the hydraulic circuit must be carefully considered. If the pressure has to be held more than 10 minutes, a hydraulic circuit with an accumulator may be energywiser.

Pressure hold function in Flow control mode

To improve the energy efficiency of the system, the rotation speed of the pump is usually reduced during the pressure holding steps. Depending on the pressure value that needs to be held, the rotation speed of the pump can be reduced down to its corresponding minimum.

Specific Circuit design for operating in pressure control mode

Operating a pump with a variable speed drive in pressure control mode requires the hydraulic circuit to be designed taking the following points into account.

- A pressure relief valve is still needed as a safety device.
- A bypass line must be included in the hydraulic circuit. It will provide the necessary cooling flow for the pump and help in stabilizing the fluid viscosity in order to achieve a stable pressure regulation. The bypass line can be activated by an on/off directional control valve when the system is above a certain pressure value and below a certain speed value.

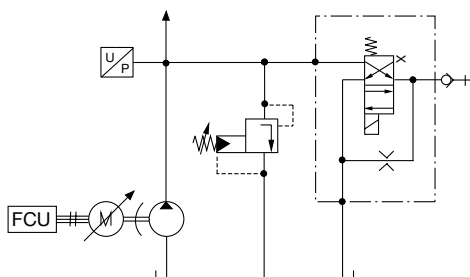

Example of bypass line circuitry :
The size of the orifice is depending on the maximum pressure value to be regulated, and the pump type.

Determination of the necessary bypass flow: $Q_{Bypass@p} = q^{vs} + Q_{Syst}$

q^{vs} : internal flow loss of the pump at the operating pressure p.

Q_{Syst} : flow amount that is necessary to compensate the leakages of the actuators and valves, and to compress the oil volume.

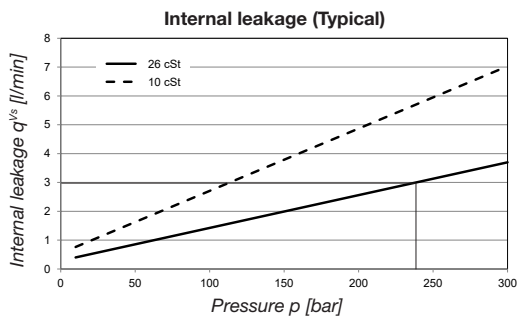

Example: Pump T7B E09 operating at p = 240 bar
ISO VG32 mineral oil at approx 45°C

$V_{i_{T7B E09}} = 28 \text{ cm}^3/\text{rev}$

Estimation based on the circuit design, $Q_{Syst} = 1 \text{ lpm}$

Value Read from the T7B technical data page, $q^{vs} = 3 \text{ lpm}$

$Q_{Bypass@p} = 3 + 1 = 4 \text{ lpm}$

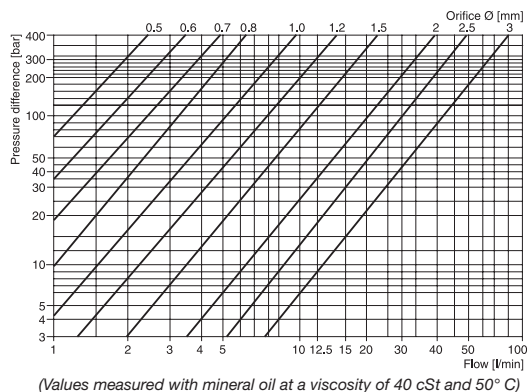

Estimation of the orifice diameter to get at least 4 lpm at 240 bar

$\Rightarrow \text{Ø } 0,7 \text{ mm}$

Decompression :

The T7 pumps for variable speed drives may be operated in a 2 quadrant mode:

- Pump mode : flow is going from the "S" to the "P" port
- Motor mode : flow is going from the "P" to the "S" port

The Rotation way described in the pump model description is corresponding to the pump mode. Never install a check valve on the "P" discharge line of the pump when a reverse rotation way is enabled.

Special care has to be taken for the transition between cycle steps, in particular for the switch of the directional control valves. When operating the pump in pressure control mode, this is of the utmost importance. In this case, the pressure set value must be ramped down before switching to flow control mode and then energizing the directional control valve.

The technology of the T7 pumps for variable speed drives is allowing a quick natural decompression of the pressure line without the need to reverse the rotation way of the E motor. Only very fast cycling machines may require to reverse the rotation way in order to decompress the pressure line in a very short time. In such a case, care must be taken that the pressure line remains positive at all time as to avoid any cavitation noise and wear to occur. Negative speed values in the range of -500 rpm could be considered.

Dynamic characteristics

The dynamic characteristic of a hydraulic system is depending on many parameters, the hydraulic pump being only one of these. This is why it is not possible in a pump catalogue to indicate precise dynamic values. We would like however to point out the following :

- The moment of inertia of the pump is mentioned on its data page of this catalogue.
- In flow control mode, the pump response time will be depending on the dynamic performances of the electric motor used, its drive unit and the oil circuitry. Flow response times in the same range or shorter than variable displacement load sensing pumps are achievable.
- When assembled to servo motors, fast drives and fast sensors, our pumps are allowing a closed loop pressure control suitable for many applications.

Example :

Fluid : 26 cSt Mineral oil
 Pump : T7B E14
 Servomotor : MH 265 Series
 Control loop system :
 - Closed loop pressure control
 - Closed loop speed control
 - Closed loop motor torque control

UP
 Acceleration from 100 to 2500 rpm
 Pressure rise from 10 to 140 bar

DOWN
 Depressurization from 140 to 10 bar
 Deceleration from 2500 to 100 rpm

Inlet line : 1.1/2"
 Inlet line : 600 mm long and flooded
 Discharge line : 1"
 Discharge length : 1200 mm

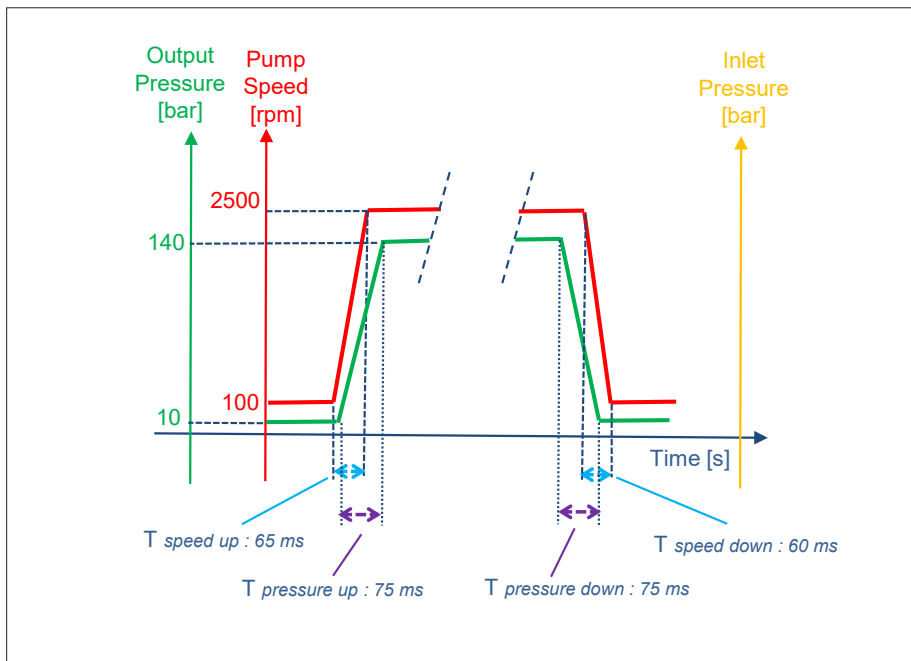

Pump installation

Pump mounting

The environment of the pump has to be taken into consideration as to avoid noise reflection, pollution and shocks. These pumps are designed to operate in any position. Always prefer an installation with a flooded inlet or with the pump inside the oil tank.

The installation of the pump on the top of the tank should be restricted to the operation in Flow Mode with moderate dynamic requirements. In such a case the inlet pipe of the pump must be sized according to the max discharge flow in order to keep the inlet velocity below 1,5 m/s.

d [mm] Inner diameter of the inlet pipe or hose
v [m/s] Average velocity
Q [L/min] Inlet flow

$$d = \sqrt{\frac{400}{6\pi} \cdot \frac{Q}{v}} \approx 4.61 \cdot \sqrt{\frac{Q}{v}}$$

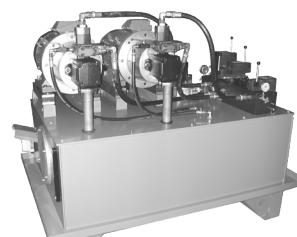
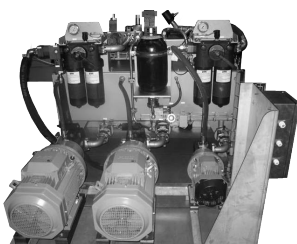
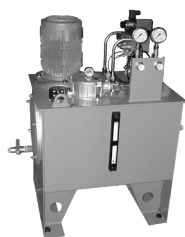

Shaft and coupling data

- **Shaft loads** : These products are primarily designed for coaxial drives which do not impose axial or side loading on the shaft. The max. permissible load values are indicated on the pump technical data page. Contact Parker for specific applications.

- **Keyed shafts** : Parker supplies its keyed shaft pumps with high strength heat-treated keys. Therefore, when installing or replacing these pumps, the heat-treated keys must be used in order to ensure maximum life in the application. If the key is replaced, it must be a heat-treated key between 27 and 34 R.C. hardness. The corners of the keys must be chamfered by 0,76 mm to 1,02 mm (0.03 to 0.04) at 45° to clear the radii in the key way.

The alignment of the keyed shafts must be within the tolerances given for the splined shafts here below.

- **Couplings and female splines** : The coupling must be selected to minimize the load on the shaft (weight, misalignment).

The female spline must be made to conform to the Class 1 fit as described in SAE-J498b (1971). This is described as a Flat Root Side Fit.

The mating female spline should be free to float and find its own center. If both members are rigidly supported, they must be aligned within 0,15 TIR (0.006" TIR) or less to reduce fretting. The angular alignment of two splines axes must be less than ± 0,05 per 25,4 radius (± 0.002" per 1" radius).

The coupling must be hardened to a hardness between 29 and 45 HRC.

The coupling spline must be lubricated with a lithium molydisulfide grease, disulfide of molybdenum or a similar lubricant.

Fluid connections

Keep a maximum distance between the suction pipe and the return lines in the tank. A bevel of min 45° on suction and return lines is recommended in order to lower the fluid velocity.

Fluid lines must be adequate size and strength to assure free flow through the pump. An undersized inlet pipe will prevent the pump from operating properly at full rated speed. An undersized outlet line will cause back pressure, heat generation and noise increase. If the pump is inside the tank, use a short inlet pipe.

Flexible hose lines are recommended. If rigid piping is used, the workmanship must be accurate to eliminate strain on the pump ports or to the fluid connections. Sharp bends in the lines must be eliminated wherever possible. All system piping must be cleaned and flushed before installing the pump.

Start-up instructions

All Parker vane pumps are individually factory tested to provide the best quality & reliability. They are to be used within the design limits indicated in our documentation. Only qualified personnel who is competent and familiar with the installation and operation of hydraulic drives and has hydraulic circuits and hydraulic equipment knowledge is allowed to put the equipment into operation. Make sure to have all necessary documentation available and always conform yourself to the valid regulations (safety, electrical, environment...).

Rotation way and ports indication

The rotation way and ports orientation are viewed from the shaft end.

CW stands for clockwise = Right-hand rotation.

CCW stands for counter-clockwise = Left-hand rotation.

Pre-start checks

Before initial starting of the pump, the following checks should be made :

- a. Check the rotation of the power source to be sure the pump shaft will rotate in the direction indicated by the arrow on the pump nameplate.
- b. Check inlet and discharge lines to be sure all connections are tight and properly connected.
- c. Check fluid type, its cleanliness and level. Make sure it can freely reach the pump inlet.

Filling, air removing & priming

The pressure relief valve should be backed off to its minimum setting value so the pump is unloaded when started. Circuit priming and air bleed off have to be performed before resetting the pressure relief valve. For priming, a minimum pump shaft speed of 600 rpm is recommended. To prevent possible damage to the internal parts, the pump should never be started dry or without internal lubrication.

- Pump with positive head : allow the fluid to flow to the pump inlet, loosen the discharge port(s) fitting(s) until the fluid comes out and re-tighten the discharge line(s). Then start the pump which should prime quite instantly. Purge the air off the circuit, preferably using air bleed off valves or pressure test points. Let the pump discharge several minutes unloaded.

- Pump mounted above fluid level : fill the pump through outlet port(s) with suitable and clean fluid and start rotation in jog mode. Purge the air off the circuit, preferably using air bleed off valves or pressure test points. Let the pump discharge several minutes unloaded.

Notes

If the pump does not prime properly or pressure cannot be obtained within seconds, it should be shut down and conditions corrected. Refer to the machine/vehicle manufacturer instructions and pump catalogue.

Maintenance

The pump is self-lubricating and its preventive maintenance is limited to keeping the hydraulic fluid clean and maintaining its viscosity within the acceptable limits. Keep all fittings and screws tight. Do not operate at pressures or speeds in excess of the recommended limits. If the pump does not operate properly, check the troubleshooting chart before attempting to overhaul the unit. The pump is fully serviceable.

**WARNING – USER RESPONSIBILITY**

FAILURE OR IMPROPER SELECTION OR IMPROPER USE OF THE PRODUCTS DESCRIBED HEREIN OR RELATED ITEMS CAN CAUSE DEATH, PERSONAL INJURY AND PROPERTY DAMAGE.

This document and other information from Parker-Hannifin Corporation, its subsidiaries and authorized distributors provide product or system options for further investigation by users having technical expertise.

The user, through its own analysis and testing, is solely responsible for making the final selection of the system and components and assuring that all performance, endurance, maintenance, safety and warning requirements of the application are met. The user must analyze all aspects of the application, follow applicable industry standards, and follow the information concerning the product in the current product catalog and in any other materials provided from Parker or its subsidiaries or authorized distributors.

To the extent that Parker or its subsidiaries or authorized distributors provide component or system options based upon data or specifications provided by the user, the user is responsible for determining that such data and specifications are suitable and sufficient for all applications and reasonably foreseeable uses of the components or systems.

Offer of Sale

Please contact your Parker representation for a detailed "Offer of Sale".

For a more complete overview of Parker product offerings, please see our interactive online marketing materials or contact one of our distributor partners.

www.parker.com





Parker Worldwide

Europe, Middle East, Africa

AE – United Arab Emirates,
Dubai

Tel: +971 4 8127100
parker.me@parker.com

AT – Austria, Wiener Neustadt
Tel: +43 (0)2622 23501-0
parker.austria@parker.com

AT – Eastern Europe, Wiener
Neustadt
Tel: +43 (0)2622 23501 900
parker.easteurope@parker.com

AZ – Azerbaijan, Baku
Tel: +994 50 22 33 458
parker.azerbaijan@parker.com

BE/LU – Belgium, Nivelles
Tel: +32 (0)67 280 900
parker.belgium@parker.com

BG – Bulgaria, Sofia
Tel: +359 2 980 1344
parker.bulgaria@parker.com

BY – Belarus, Minsk
Tel: +48 (0)22 573 24 00
parker.poland@parker.com

CH – Switzerland, Etoy
Tel: +41 (0)21 821 87 00
parker.switzerland@parker.com

CZ – Czech Republic, Klecany
Tel: +420 284 083 111
parker.czechrepublic@parker.com

DE – Germany, Kaarst
Tel: +49 (0)2131 4016 0
parker.germany@parker.com

DK – Denmark, Ballerup
Tel: +45 43 56 04 00
parker.denmark@parker.com

ES – Spain, Madrid
Tel: +34 902 330 001
parker.spain@parker.com

FI – Finland, Vantaa
Tel: +358 (0)20 753 2500
parker.finland@parker.com

FR – France, Contamine s/Arve
Tel: +33 (0)4 50 25 80 25
parker.france@parker.com

GR – Greece, Athens
Tel: +30 210 933 6450
parker.greece@parker.com

HU – Hungary, Budaörs
Tel: +36 23 885 470
parker.hungary@parker.com

IE – Ireland, Dublin
Tel: +353 (0)1 466 6370
parker.ireland@parker.com

IT – Italy, Corsico (MI)
Tel: +39 02 45 19 21
parker.italy@parker.com

KZ – Kazakhstan, Almaty
Tel: +7 7273 561 000
parker.easteurope@parker.com

NL – The Netherlands, Oldenzaal
Tel: +31 (0)541 585 000
parker.nl@parker.com

NO – Norway, Asker
Tel: +47 66 75 34 00
parker.norway@parker.com

PL – Poland, Warsaw
Tel: +48 (0)22 573 24 00
parker.poland@parker.com

PT – Portugal
Tel: +351 22 999 7360
parker.portugal@parker.com

RO – Romania, Bucharest
Tel: +40 21 252 1382
parker.romania@parker.com

RU – Russia, Moscow
Tel: +7 495 645-2156
parker.russia@parker.com

SE – Sweden, Spånga
Tel: +46 (0)8 59 79 50 00
parker.sweden@parker.com

SK – Slovakia, Banská Bystrica
Tel: +421 484 162 252
parker.slovakia@parker.com

SL – Slovenia, Novo Mesto
Tel: +386 7 337 6650
parker.slovenia@parker.com

TR – Turkey, Istanbul
Tel: +90 216 4997081
parker.turkey@parker.com

UA – Ukraine, Kiev
Tel: +48 (0)22 573 24 00
parker.poland@parker.com

UK – United Kingdom, Warwick
Tel: +44 (0)1926 317 878
parker.uk@parker.com

ZA – South Africa, Kempton Park
Tel: +27 (0)11 961 0700
parker.southafrica@parker.com

North America

CA – Canada, Milton, Ontario
Tel: +1 905 693 3000

US – USA, Cleveland
(industrial)
Tel: +1 216 896 3000

US – USA, Elk Grove Village
(mobile)
Tel: +1 847 258 6200

Asia Pacific

AU – Australia, Castle Hill
Tel: +61 (0)2-9634 7777

CN – China, Shanghai
Tel: +86 21 2899 5000

HK – Hong Kong
Tel: +852 2428 8008

ID – Indonesia, Tangerang
Tel: +62 21 7588 1906

IN – India, Mumbai
Tel: +91 22 6513 7081-85

JP – Japan, Fujisawa
Tel: +81 (0)4 6635 3050

KR – South Korea, Seoul
Tel: +82 2 559 0400

MY – Malaysia, Shah Alam
Tel: +60 3 7849 0800

NZ – New Zealand, Mt Wellington
Tel: +64 9 574 1744

SG – Singapore
Tel: +65 6887 6300

TH – Thailand, Bangkok
Tel: +662 186 7000

TW – Taiwan, New Taipei City
Tel: +886 2 2298 8987

VN – Vietnam, Ho Chi Minh City
Tel: +84 8 3999 1600

South America

AR – Argentina, Buenos Aires
Tel: +54 3327 44 4129

BR – Brazil, Cachoeirinha RS
Tel: +55 51 3470 9144

CL – Chile, Santiago
Tel: +56 2 623 1216

MX – Mexico, Toluca
Tel: +52 72 2275 4200



EMEA Product Information Centre

Free phone: 00 800 27 27 5374

(from AT, BE, CH, CZ, DE, DK, EE, ES, FI, FR, IE, IL,
IS, IT, LU, MT, NL, NO, PL, PT, RU, SE, SK, UK, ZA)

US Product Information Centre

Toll-free number: 1-800-27 27 537

www.parker.com

Your local authorized Parker distributor